

A G E N D A
JAMES CITY COUNTY CHESAPEAKE BAY BOARD
REGULAR MEETING
County Government Center, Building F
101 Mounts Bay Road, Williamsburg, VA 23185
September 12, 2018
5:00 PM

A. CALL TO ORDER

B. ROLL CALL

C. MINUTES

1. Minutes from the August 8, 2018 regular meeting

D. PUBLIC HEARINGS

1. CBPA 18-0129 : 343 Neck-O-Land Road
2. CBPA 18-0131 : 113 Wareham's Point
3. CBPA 18-0149 : 213 Southpoint Drive
4. CBPA 18-0126 : 3936 Vass Lane
5. CBPA 18-0134 : 500 Thompson Lane
6. CBPA 18-0148 : Busch Gardens, Festa Italia

E. BOARD CONSIDERATIONS

F. MATTERS OF SPECIAL PRIVILEGE

G. ADJOURNMENT

ITEM SUMMARY

DATE: 9/12/2018
TO: Chesapeake Bay Board
FROM: Chesapeake Bay Board Secretary
SUBJECT: Minutes from the August 8, 2018 regular meeting

ATTACHMENTS:

	Description	Type
☐	Minutes	Minutes

REVIEWERS:

Department	Reviewer	Action	Date
Chesapeake Bay Group	Woolson, Michael	Approved	8/28/2018 - 2:57 PM
Chesapeake Bay Group	Geissler, Fran	Approved	8/28/2018 - 7:20 PM
Publication Management	Burcham, Nan	Approved	8/29/2018 - 7:35 AM
Chesapeake Bay Group	Secretary, ChesBay	Approved	9/6/2018 - 1:24 PM

MINUTES
JAMES CITY COUNTY CHESAPEAKE BAY BOARD
REGULAR MEETING
County Government Center, Building F
101 Mounts Bay Road, Williamsburg, VA 23185
August 8, 2018
5:00 PM

A. CALL TO ORDER

The Chesapeake Bay Board meeting for August 8, 2018, was called to order.

The responsibility of this Board is to carry out locally the Commonwealth policy to protect against and minimize pollution and deposition of sediment in wetlands, streams and lakes in James City County, which are tributaries of the Chesapeake Bay.

B. ROLL CALL

Board Members Present:

William Apperson, Vice Chair
Larry Waltrip
John Hughes

Board Members Absent:

David Gussman, Chair
Charles Roadley
Louis Bott

County Staff Present:

Michael Woolson, Secretary to the Board, Senior Watershed Planner,
Stormwater and Resource Protection
Frances Geissler, Director, Stormwater and Resource Protection
Liz Parman, Assistant County Attorney
Trevor Long, Watershed Planner, Stormwater and Resource Protection
Janice Petty, Assistant, Stormwater and Resource Protection

C. MINUTES

1. Minutes from June 13, 2018, regular meeting

The minutes from the June 13, 2018, regular meeting were approved as written.

Mr. Hughes made the motion to accept the minutes.

D. PUBLIC HEARINGS

Prior to starting the public hearings, Staff formally reminded the Board, all applicants and the public that three affirmative votes are required for approvals.

1. CBPA 18-0108 : 2917 Leatherleaf Drive

Mr. Edwin Keusey has applied for a Chesapeake Bay Exception for encroachments into the Resource Protection Area (RPA) buffer for the construction of a new attached deck on the

property located at 2917 Leatherleaf Drive in the Stonehouse subdivision and the Ware Creek watershed. The property is further identified as James City County Tax Map Parcel No. 0510200010. Staff has reviewed the Sensitive Area Activity application and exception request and has determined impacts associated with the proposal to be minor for the proposed development. Staff recommends approval of the application with conditions.

The Board deliberated on the pros and cons of this application.

Mr. Hughes asked if there still would be stairs.

Mr. Long deferred to the applicant.

Mr. Waltrip questioned if there were any trees to be removed.

Mr. Long replied no trees would be removed.

Mr. Apperson opened the Public Hearing.

A. Mr. Edwin Keusey, applicant, addressed the Board and responded to questions.

Mr. Waltrip inquired if the deck elevation would be the same or would it be a step down deck.

A. Mr. Keusey responded, two steps down and new deck would be at that level.

Mr. Hughes asked if the steps down would be in the same footprint.

A. Mr. Keusey replied that the new deck would be at the third step height, with new stairs in the opposite direction.

Mr. Apperson closed the Public Hearing, as no one else wished to speak.

Mr. Hughes made a motion to grant the application for Chesapeake Bay Board Case No. CBPA-18-0108 at 2917 Leatherleaf Drive.

The motion was approved: 3-0
Ayes: Waltrip, Hughes, Apperson
Nays: None
Absent: Gussman, Roadley, Bott

2. CBPA-18-0121 : 103 Bermuda Circle

Mr. Dustin Turlington, Crossroad Custom Builders, on behalf of Ms. Janet Thrall, has applied for a Chesapeake Bay Exception for encroachments into the RPA buffer for construction of a detached garage on the property located at 103 Bermuda Circle in the First Colony subdivision and the James River watershed. The property is further identified as James City County Tax Map Parcel No. 4540200172. Staff has reviewed the Sensitive Area Activity application and exception request and has determined impacts associated with the proposal to be minor for the proposed development. Staff recommends approval of the application with conditions.

The Board deliberated on the pros and cons of this application.

Mr. Apperson opened the Public Hearing.

A. Mr. Shawn Lemon, Crossroad Custom Builders, addressed the Board and responded to questions.

Mr. Apperson asked if they were putting in the rain garden also with guidance from the County staff.

A. Mr. Lemon replied that they were putting in the rain garden.

Mr. Apperson closed the Public Hearing, as no one else wished to speak.

Mr. Hughes made a motion for Chesapeake Bay Board Case No. CBPA-18-0121 at 103 Bermuda Circle.

The motion was approved: 3-0
Ayes: Waltrip, Hughes, Apperson
Nays: None
Absent: Gussman, Roadley, Bott

3. CBPA 18-0122 : 2148 Benomi Drive

Tabitha and Robert Partlow have applied for a Chesapeake Bay Exception for encroachments into the RPA buffer for the construction of a shed on the property located at 2148 Benomi Drive within the Peleg's Point subdivision and the Mill Creek watershed. The property is further identified as James City County Tax Map Parcel No. 4741300084. Staff has reviewed the application and exception request and has determined impacts associated with the proposal to be minor for the proposed development. Staff recommends approval of the application with conditions.

The Board deliberated on the pros and cons of this application.

Mr. Apperson opened the Public Hearing.

Mr. Apperson closed the Public Hearing, as no one wished to speak.

Mr. Hughes stated that he would like the structure corners to be staked out in the field for future presentations.

Mr. Hughes made a motion to grant the application for Chesapeake Bay Board Case No. CBPA-18-0122 at 2148 Benomi Drive.

The motion was approved: 3-0
Ayes: Waltrip, Hughes, Apperson
Nays: None
Absent: Gussman, Roadley, Bott

4. CBPA 18-0128 : 4131 Centerville Road

Mr. Michael Woolson presented the updated exception request submitted by Joe Franklin of Greensprings Mobile Home Park, LLC for encroachments into the RPA buffer for the construction of a new principle structure. The project is located on the property known as 4131 Centerville Road in the Gordon Creek Watershed. The property is further identified as James City County Tax Map Parcel No. 3640100001. Staff has also determined that the impacts with this proposal to be major for the proposed development. Staff recommends approval with conditions.

The Board deliberated on the pros and cons of this application.

Mr. Apperson continued the Public Hearing.

A. John Franklin, Franklin Management, addressed the Board and responded to questions.

Mr. Apperson closed the Public Hearing, as no one else wished to speak.

Mr. Hughes made a motion to grant the application for Chesapeake Bay Board Case No. CBPA-18-0128 at 4131 Centerville Road.

The motion was approved: 3-0
Ayes: Waltrip, Hughes, Apperson
Nays: None
Absent: Gussman, Roadley, Bott

E. BOARD CONSIDERATIONS

None

F. MATTERS OF SPECIAL PRIVILEGE

None

G. ADJOURNMENT

The meeting was adjourned at 5:58 p.m.

ITEM SUMMARY

DATE: 9/12/2018

TO: Chesapeake Bay Board

FROM: Michael Woolson, Senior Watershed Planner

SUBJECT: CBPA-18-0129 : 343 Neck-O-Land Road

ATTACHMENTS:

	Description	Type
☐	APO Letter	Cover Memo
☐	APO Mailing List	Cover Memo
☐	Site Plan	Cover Memo
☐	Staff Report	Cover Memo
☐	Resolution	Cover Memo
☐	Public Notice	Cover Memo

REVIEWERS:

Department	Reviewer	Action	Date
Chesapeake Bay Group	Geissler, Fran	Approved	9/5/2018 - 3:47 PM
Chesapeake Bay Group	Geissler, Fran	Approved	9/5/2018 - 3:47 PM
Publication Management	Burcham, Nan	Approved	9/5/2018 - 4:09 PM
Chesapeake Bay Group	Secretary, ChesBay	Approved	9/6/2018 - 7:13 AM



**General Services
Stormwater and Resource
Protection Division**
101-E Mounts Bay Road
Williamsburg, VA 23185
757-253-6790

Resource.Protection@jamescitycountyva.gov

August 22, 2018

RE: CBPA-18-0129 – 343 Neck-O-Land Road
Shed

Dear Adjacent Property Owner:

In accordance with State and County Codes, this letter is to notify you that a request has been filed with the James City County Chesapeake Bay Board by Jefferson Davis for encroachment into the Resource Protection Area (RPA) buffer associated with the construction of a shed. The project is located at 343 Neck-O-Land Road and is further identified as JCC Parcel No. 4730100055.

A complete description, plan and other information are on file in the Stormwater and Resource Protection Division and are available for inspection during normal business hours should anyone desire to review them.

The Chesapeake Bay Board will hold an advertised public hearing on **Wednesday, September 12, 2018 at 5:00 p.m.**, in the Board Room of Building F, 101-F, Mounts Bay Road, James City County, Virginia, at which time you may request to speak on the above referenced project.

Sincerely,

Janice Petty

Janice Petty
Stormwater Assistant

cc: Applicant /Owner

Mailing List for: CBPA-18-0129 – 343 Neck-O-Land Road – Davis– Shed

Owner: 4730100055

4730100054-10.61 A

Davis, Jefferson H, Jr. & Mary Ellen

343 Neck-O-Land Road

Williamsburg, VA 23185-3133

4730400001-339 Neck-O-Land Road

Williams, Kevin

P.O. Box 3272

Merrifield, VA 22116-3272

4730100056

Rogers, Ronald K & Maria M

341 Neck-O-Land Road

Williamsburg, VA 23185-3113

4730100057-403 Neck-O-Land Road

Hewlett, Robert E & Paige I

516 Neck-O-Land Road

Williamsburg, VA 23185-3137

4732400001A-25.57 A Common Area P-4 Landfall at Jamestown

Landfall at Jamestown Community Association

103 Bulifants Boulevard, Suite A

Williamsburg, VA 23188-5722



REF: #343 NECK - O. LAND ROAD
 DB 136/L31
 DB 176/522

EVANS SURVEYING, LLC
 236 B Merrimac Trail
 Williamsburg, Virginia 23185
 (757) 592-5855

J.O. No. 0526

Nov. 14, 2005

JAMES CITY COUNTY, VA.
 GLENN W & LORENA A. WILLIAMS
 FOR CONVEYANCE TO
 #343 NECK - O. LAND ROAD
 PHYSICAL SURVEY

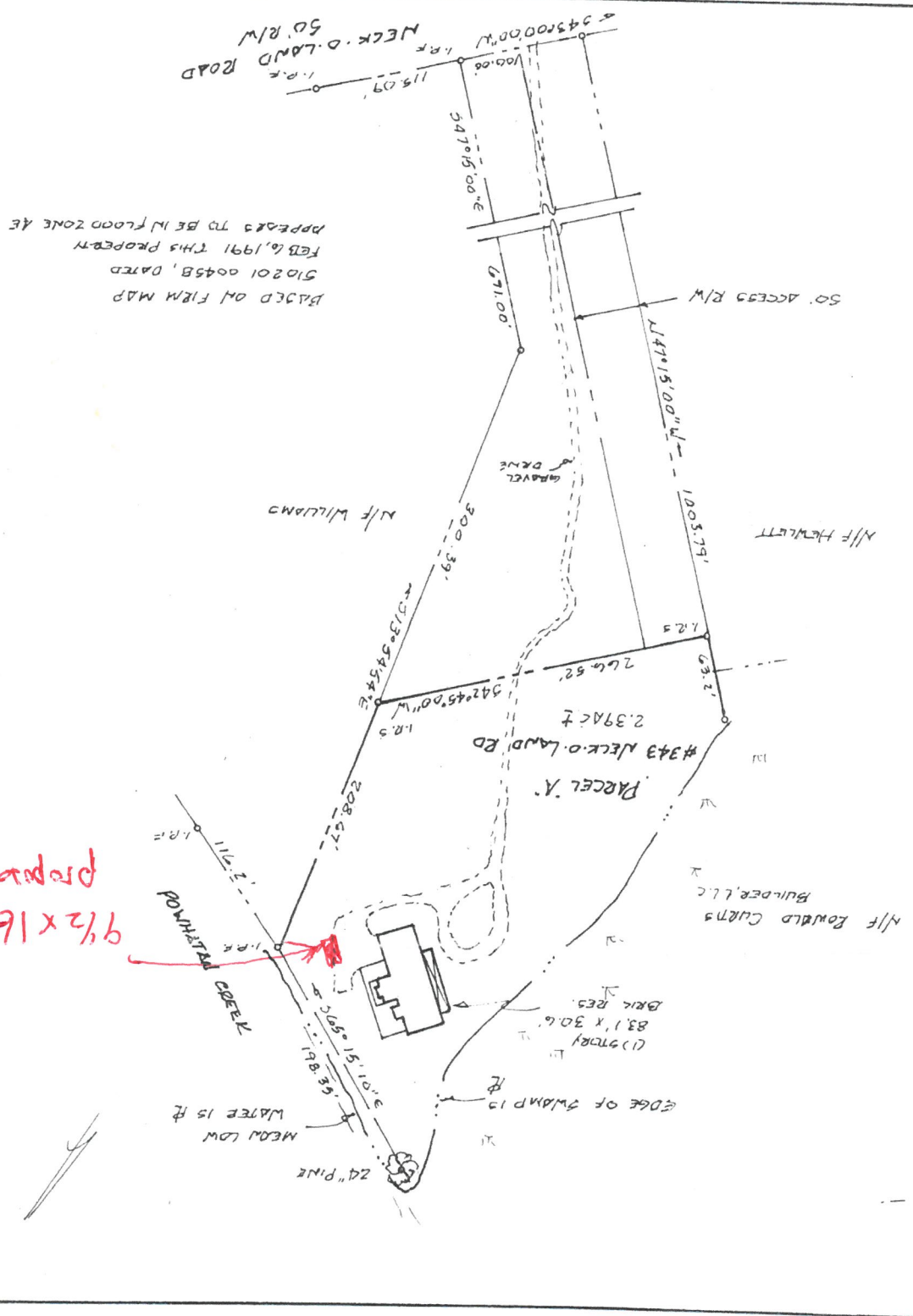

BASED ON FIRM MAP
 510201 0045B, DATED
 FEB 6, 1991 THIS PROPERTY
 APPEARS TO BE IN FLOOD ZONE AE

9 1/2 x 16' shed
 proposed location

757 229-5464
 811 miles
 2 miles
 2 miles

**CHESAPEAKE BAY BOARD EXCEPTION No. CBPA-18-0129. 343 Neck-O-Land Road
Staff Report for the September 12, 2018, Chesapeake Bay Board Public Hearing**

This staff report is prepared by James City County Stormwater and Resource Protection to provide information to the Chesapeake Bay Board to assist them in making a recommendation on this assessment. It may be useful to members of the general public interested in this assessment.

EXISTING SITE DATA AND INFORMATION

Applicant: Mr. Jeff Davis

Agent: None

Location: 343 Neck-O-Land Road

Tax Map/Parcel No.: 4730100055

Parcel: Part A, Pt Neck-O-Land

Lot Size: 2.39 acres

Area of Lot in Resource Protection Area (RPA): 2.39 acres +/- (100%)

Watershed: Powhatan Creek (HUC JL 31)

Floodplain: Zone AE - Base flood elevation determined to be 7 feet mean sea level

Proposed Activity: Construction of a shed

Impervious Cover: 152 square feet

RPA Encroachment: 152 square feet, seaward 50-foot RPA buffer

Staff Contact: Trevor Long, Watershed Planner Phone: 253-6789

BRIEF SUMMARY AND DESCRIPTION OF ACTIVITIES

Mr. Jeff Davis has applied for a Chesapeake Bay Exception for encroachments into the RPA buffer for the construction of a shed on property located at 343 Neck-O-Land Road within the Powhatan Creek watershed. The property is further identified as James City County Tax Map Parcel No. 4730100055. The parcel was platted in 1977, prior to the adoption of the Chesapeake Bay Preservation Ordinance in 1990.

The total lot size of this property is 2.39 acres, of which 100% is located within the RPA. Due to the nature of the lot, RPA encroachment is unavoidable for the construction of a shed on this property. The total impervious encroachment within the RPA is 115 square feet within the seaward 50-foot RPA. At this time, the applicant has not proposed a mitigation plan, however, required mitigation for this amount of impact would be the plantings of one canopy tree and three shrubs.

STAFF EVALUATION

Staff has evaluated the application and exception request for the construction of the shed and finds that the application meets the conditions in Sections 23-11 and 23-14 and that the application should be heard by the

Board because the shed is accessory in nature. Therefore, this request must be considered by the Board following a public hearing under the formal exception process. Per Sections 23-11 and 23-14 of the County Ordinance, a Water Quality Impact Assessment (WQIA) was submitted for the proposed project.

CONSIDERATION BY THE CHESAPEAKE BAY BOARD

The exception granting body is permitted to require reasonable and appropriate conditions in granting the exception request in accordance with Section 23-14. The Chesapeake Bay Board should fully consider Chesapeake Bay Exception CBPA-18-0129 as outlined and presented above and review the request for exception along with the WQIA. The Board may grant the exception with such conditions and safeguards as deemed necessary to further the purpose and intent of the County's Chesapeake Bay Preservation Ordinance.

STAFF RECOMMENDATIONS

Staff has reviewed the application and exception request and has determined impacts associated with the proposal to be minor for the proposed development. Staff recommends approval of this exception request with the following conditions incorporated into the approval:

1. The applicant must obtain all other necessary federal, state and local permits as required for the project.
2. All development activities located in the special flood hazard area shall comply with Article VI, Division 3, Floodplain Area Regulations of the James City County Zoning Ordinance and receive all required approvals and permits prior to commencement of such activities.
3. A mitigation plan consistent with County requirements be submitted along with a surety of \$250 in a form acceptable to the James City County Attorney to ensure the mitigation.
4. This exception request approval shall become null and void if construction has not begun by September 12, 2019.
5. Written requests for an extension to an exception shall be submitted to the Stormwater and Resource Protection Division no later than six weeks prior to the expiration date.

TL/nb
CBPA18-129-343NkOLndRd

Attachments:

1. Resolution
2. Water Quality Impact Assessment Package
3. Site Plan

RESOLUTION

CASE NO. CBPA-18-0129. 343 NECK-O-LAND ROAD

JAMES CITY COUNTY CHESAPEAKE BAY PRESERVATION ORDINANCE EXCEPTION

WHEREAS, Mr. Jeff Davis (the “Applicant”) has applied to the Chesapeake Bay Board of James City County (the “Board”) on September 12, 2018, to request an exception to use the Resource Protection Area (the “RPA”) on a parcel of property identified as James City County Real Estate Tax Parcel No. 4730100055 and further identified as 343 Neck-O-Land Road (the “Property”) as set forth in the application CBPA-18-0129 for the purpose of the construction of a shed; and

WHEREAS, the Board has listened to the arguments presented and has carefully considered all evidence entered into the record.

NOW, THEREFORE, BE IT RESOLVED that the Chesapeake Bay Board of James City County, Virginia, following a public hearing, by a majority vote of its members FINDS that:

1. The exception request is the minimum necessary to afford relief.
2. Granting the exception will not confer upon the Applicant any special privileges denied by Chapter 23, Chesapeake Bay Preservation, of the James City County Code, to other property owners similarly situated in the vicinity.
3. The exception request will be in harmony with the purpose and intent of Chapter 23 of the James City County Code and is not of substantial detriment to water quality.
4. The exception request is not based on conditions or circumstances that are self-created or self-imposed, nor does the request arise from conditions or circumstances either permitted or non-conforming that are related to adjacent parcels.
5. Reasonable and appropriate conditions are hereby imposed, as set forth below, which will prevent the exception request from causing a degradation of water quality.
6. In granting this exception, the following conditions are hereby imposed to prevent this exception request from causing degradation of water quality:
 - a. The applicant must obtain all other necessary federal, state and local permits required for the project.
 - b. All development activities located in the special flood hazard area shall comply with Article VI, Division 3, Floodplain Area Regulations of the James City County Zoning Ordinance and receive all required approvals and permits prior to commencement of such activities.

- c. A mitigation plan congruent with County requirements be submitted along with a surety of \$250 in a form acceptable to the James City County Attorney to ensure the mitigation.
- d. This exception request approval shall become null and void if construction has not begun by September 12, 2019.
- e. Written requests for an extension to an exception shall be submitted to the Stormwater and Resource Protection Division no later than six weeks prior to the expiration date.

David Gussman
Chair, Chesapeake Bay Board

Michael D. Woolson
Senior Watershed Planner

Adopted by the Chesapeake Bay Board of James City County, Virginia, this 12th day of September, 2018.

THE FOREGOING INSTRUMENT WAS ACKNOWLEDGED BEFORE ME THIS ____ DAY OF _____, 20__ IN THE COMMONWEALTH OF VIRGINIA, IN THE COUNTY OF JAMES CITY.

NOTARY PUBLIC

MY COMMISSION EXPIRES: _____

CBPA18-129-343NkOLndRd-res



PUBLIC HEARING NOTICE

THE WETLANDS AND CHESAPEAKE BAY BOARDS OF JAMES CITY COUNTY, VIRGINIA WILL HOLD A PUBLIC HEARING ON **WEDNESDAY, SEPTEMBER 12, 2018, AT 5 P.M.** IN THE BOARD ROOM OF BUILDING E, 101 MOUNTS BAY ROAD, JAMES CITY COUNTY, VIRGINIA.

THE WETLANDS BOARD WILL CONSIDER THE FOLLOWING CASE:

WJPA 18-0070/VMRC 17-0133: William & Mary Sailing Club has applied for a wetland permit to construct a floating dock at the Kingsmill Marina, 1010 Kingsmill Road in the Kingsmill on the James subdivision, JCC Parcel No. 5040100002C.

THE CHESAPEAKE BAY BOARD WILL CONSIDER THE FOLLOWING CASES:

CBPA 18-0129: Mr. Jeff Davis has filed an exception request for encroachment into the RPA buffer for the construction of a shed at 343 Neck-O-Land Road in the Berkeley District, JCC Parcel No. 4730100055.

CBPA 18-0134: Mr. and Mrs. N. Ross and Amy Thompson have filed an exception request for encroachment into the RPA buffer for the construction of a single family dwelling, deck, patio, retaining walls and a barn addition at 500 Thompson Lane in the Powhatan District, JCC Parcel No. 3610100005.

CBPA 18-0148: SeaWorld Parks and Entertainment has filed an exception request for encroachment into the RPA buffer for the construction of a new structure in the Festa Italia section of Busch Gardens Williamsburg at 7851 Pocahontas Trail, JCC Parcel No. 55140100009.

CBPA 18-0149: Ms. Meredith Robertson has filed an exception request for encroachment into the RPA buffer for the construction of two retaining walls at 213 Southpoint Drive in the Kingspoint subdivision, JCC Parcel No. 4930270014.

CBPA 18-0126: Mr. John Hyland has filed an exception request for encroachment into the RPA buffer for the construction of a detached workshop at 3936 Vass Lane in the Vass Meadows subdivision, JCC Parcel No. 3842100009.

CBPA 18-0131: Ms. Jean Walker has filed an exception request for encroachment into the RPA buffer for the construction of a retaining wall at 113 Wareham's Point in the Kingsmill on the James subdivision, JCC Parcel No. 5041900113.

Appeals from decisions under the Chesapeake Bay Preservation Ordinance may also be heard.

All interested parties are invited to attend the meetings. The applications and plans are on file and may be viewed during normal office hours in the Stormwater and Resource Protection Division, 101 Mounts Bay Road, Building E, James City County, Virginia.

ITEM SUMMARY

DATE: 9/12/2018
TO: Chesapeake Bay Board
FROM: Michael Woolson, Senior Watershed Planner
SUBJECT: CBPA 18-0131 : 113 Wareham's Point

ATTACHMENTS:

	Description	Type
☐	APO Mailing List	Cover Memo
☐	APO Letter	Cover Memo
☐	Public Notice	Cover Memo
☐	Site Plan	Cover Memo
☐	Staff Report	Cover Memo
☐	Resolution	Cover Memo

REVIEWERS:

Department	Reviewer	Action	Date
Chesapeake Bay Group	Geissler, Fran	Approved	9/5/2018 - 3:48 PM
Chesapeake Bay Group	Geissler, Fran	Approved	9/5/2018 - 3:48 PM
Publication Management	Burcham, Nan	Approved	9/5/2018 - 4:08 PM
Chesapeake Bay Group	Secretary, ChesBay	Approved	9/6/2018 - 1:23 PM

Mailing List for: CBPA-18-0131 – 113 Wareham’s Point – Walker – Retaining Wall

Owner: 5041900113

Walker, Miley Wesson & Jean Shelton
710 North Broad Street
Suffolk, VA 23434-4908

Walker, Miley Wesson & Jean Shelton
113 Wareham’s Point
Williamsburg, VA 23185-8914

5041900111-111 Wareham’s Point

Agnor, Jane C
76 Osprey Lane
Locust Hill, VA 23092-9707

5041900115

Saunders, Patricia B, Trustee
115 Wareham’s Point
Williamsburg, VA 23185-8914

5041900001-107 Wareham’s Point

Kingsmill Community Service Association
P.O. Box 348
Williamsburg, VA 23187-0348



**General Services
Stormwater and Resource
Protection Division**
101-E Mounts Bay Road
Williamsburg, VA 23185
757-253-6790

Resource.Protection@jamescitycountyva.gov

August 22, 2018

RE: CBPA-18-0131 – 113 Warehams Point
Retaining Wall

Dear Adjacent Property Owner:

In accordance with State and County Codes, this letter is to notify you that a request has been filed with the James City County Chesapeake Bay Board by Miley and Jean Walker for encroachment into the Resource Protection Area (RPA) buffer associated with the construction of a retaining wall. The project is located at 113 Warehams Point in the Warehams Point subdivision located in the Kingsmill on the James subdivision and is further identified as JCC Parcel No. 5041900113.

A complete description, plan and other information are on file in the Stormwater and Resource Protection Division and are available for inspection during normal business hours should anyone desire to review them.

The Chesapeake Bay Board will hold an advertised public hearing on **Wednesday, September 12, 2018 at 5:00 p.m.**, in the Board Room of Building F, 101-F, Mounts Bay Road, James City County, Virginia, at which time you may request to speak on the above referenced project.

Sincerely,

Janice Petty

Janice Petty
Stormwater Assistant

cc: Applicant /Owner



PUBLIC HEARING NOTICE

THE WETLANDS AND CHESAPEAKE BAY BOARDS OF JAMES CITY COUNTY, VIRGINIA WILL HOLD A PUBLIC HEARING ON **WEDNESDAY, SEPTEMBER 12, 2018, AT 5 P.M.** IN THE BOARD ROOM OF BUILDING E, 101 MOUNTS BAY ROAD, JAMES CITY COUNTY, VIRGINIA.

THE WETLANDS BOARD WILL CONSIDER THE FOLLOWING CASE:

WJPA 18-0070/VMRC 17-0133: William & Mary Sailing Club has applied for a wetland permit to construct a floating dock at the Kingsmill Marina, 1010 Kingsmill Road in the Kingsmill on the James subdivision, JCC Parcel No. 5040100002C.

THE CHESAPEAKE BAY BOARD WILL CONSIDER THE FOLLOWING CASES:

CBPA 18-0129: Mr. Jeff Davis has filed an exception request for encroachment into the RPA buffer for the construction of a shed at 343 Neck-O-Land Road in the Berkeley District, JCC Parcel No. 4730100055.

CBPA 18-0134: Mr. and Mrs. N. Ross and Amy Thompson have filed an exception request for encroachment into the RPA buffer for the construction of a single family dwelling, deck, patio, retaining walls and a barn addition at 500 Thompson Lane in the Powhatan District, JCC Parcel No. 3610100005.

CBPA 18-0148: SeaWorld Parks and Entertainment has filed an exception request for encroachment into the RPA buffer for the construction of a new structure in the Festa Italia section of Busch Gardens Williamsburg at 7851 Pocahontas Trail, JCC Parcel No. 55140100009.

CBPA 18-0149: Ms. Meredith Robertson has filed an exception request for encroachment into the RPA buffer for the construction of two retaining walls at 213 Southpoint Drive in the Kingspoint subdivision, JCC Parcel No. 4930270014.

CBPA 18-0126: Mr. John Hyland has filed an exception request for encroachment into the RPA buffer for the construction of a detached workshop at 3936 Vass Lane in the Vass Meadows subdivision, JCC Parcel No. 3842100009.

CBPA 18-0131: Ms. Jean Walker has filed an exception request for encroachment into the RPA buffer for the construction of a retaining wall at 113 Wareham's Point in the Kingsmill on the James subdivision, JCC Parcel No. 5041900113.

Appeals from decisions under the Chesapeake Bay Preservation Ordinance may also be heard.

All interested parties are invited to attend the meetings. The applications and plans are on file and may be viewed during normal office hours in the Stormwater and Resource Protection Division, 101 Mounts Bay Road, Building E, James City County, Virginia.

CBPA-18-0131

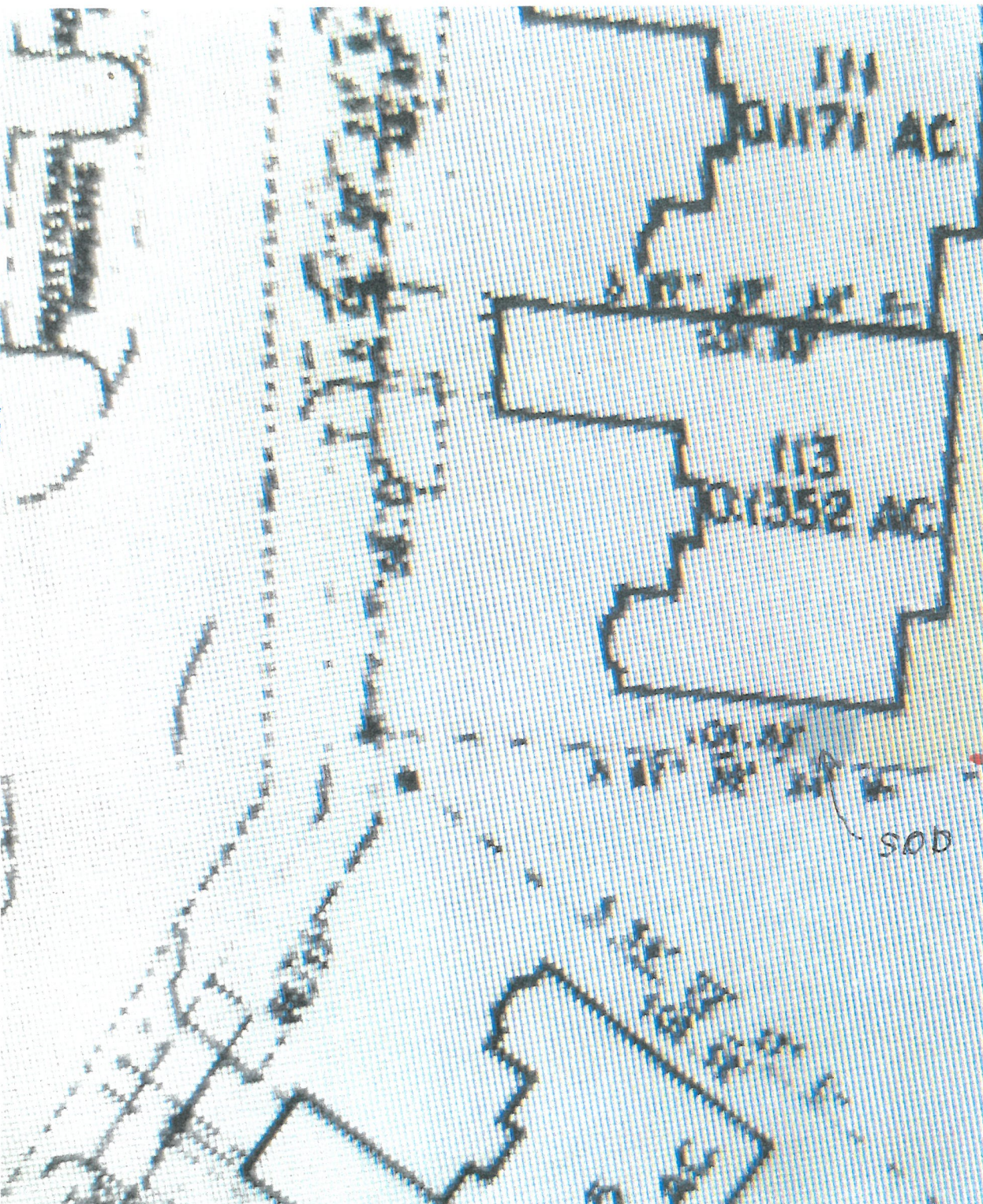

WALL 2-3'

STONE MULCH

SOD

JERN WALKER
113 WRENTHAM POINT

**CHESAPEAKE BAY BOARD EXCEPTION No. CBPA-18-0131. 113 Warehams Point
Staff Report for the September 12, 2018, Chesapeake Bay Board Public Hearing**

This staff report is prepared by James City County Stormwater and Resource Protection to provide information to the Chesapeake Bay Board to assist them in making a recommendation on this assessment. It may be useful to members of the general public interested in this assessment.

EXISTING SITE DATA AND INFORMATION

Applicants: Miley and Jean Walker

Agent: None

Location: 113 Warehams Point

Tax Map/Parcel No.: 5041900113

Parcel: Lot 113, Warehams Point, Kingsmill on the James

Lot Size: .14 acre

Area of Lot in Resource Protection Area (RPA): .05 acres +/- (35%)

Watershed: Skiffes Creek (HUC JL 35)

Floodplain: None

Proposed Activity: Construction of a retaining wall

Impervious Cover: 70 square feet

RPA Encroachment: 70 square feet, landward 50-foot RPA buffer

Staff Contact: Trevor Long, Watershed Planner Phone: 253-6789

BRIEF SUMMARY AND DESCRIPTION OF ACTIVITIES

Miley and Jean Walker have applied for a Chesapeake Bay Exception for encroachments into the RPA buffer for the construction of a retaining wall on property located at 113 Warehams Point within the Kingsmill on the James subdivision and the Skiffes Creek watershed. The property is further identified as James City County Tax Map Parcel No. 5041900113. The parcel was platted in 1990.

During the spring of 2018, staff met with the applicants to discuss the erosion issues on property located behind 113 Warehams Point. During this meeting, it was observed that water flowing from upslope of the property has been causing erosion at the edge of the slope. Because of the proximity of the edge of the slope to the corner of the house, the erosion is causing dangerous walking conditions for the homeowners. For this reason, staff suggested that the applicants construct a retaining wall to provide a more level walking area and reduce erosion. To mitigate for the 70 feet of proposed disturbance for this project, staff requires the plantings of three shrubs. The applicants have proposed the plantings of two native understory trees, therefore exceeding County mitigation requirements.

STAFF EVALUATION

Staff has evaluated the application and exception request for the construction of the retaining wall and finds that the application meets the conditions in Sections 23-11 and 23-14 and that the application should be heard by the Board because the retaining wall is accessory in nature. Therefore, this request must be considered by the Board following a public hearing under the formal exception process. Per Sections 23-11 and 23-14 of the County Ordinance, a Water Quality Impact Assessment (WQIA) was submitted for the proposed project.

CONSIDERATION BY THE CHESAPEAKE BAY BOARD

The exception granting body is permitted to require reasonable and appropriate conditions in granting the exception request in accordance with Section 23-14. The Chesapeake Bay Board should fully consider Chesapeake Bay Exception CBPA-18-0131 as outlined and presented above and review the request for exception along with the WQIA. The Board may grant the exception with such conditions and safeguards as deemed necessary to further the purpose and intent of the County's Chesapeake Bay Preservation Ordinance.

STAFF RECOMMENDATIONS

Staff has reviewed the application and exception request and has determined impacts associated with the proposal to be minor for the proposed development. Staff recommends approval of this exception request with the following conditions incorporated into the approval:

1. The applicant must obtain all other necessary federal, state and local permits as required for the project.
2. A surety of \$250 in a form acceptable to the James City County Attorney to ensure the mitigation.
3. This exception request approval shall become null and void if construction has not begun by September 12, 2019.
4. Written requests for an extension to an exception shall be submitted to the Stormwater and Resource Protection Division no later than six weeks prior to the expiration date.

TL/md
CBPA18-0131WarehamsPt

Attachments:

1. Resolution
2. Water Quality Impact Assessment Package
3. Site Plan

RESOLUTION

CASE NO. CBPA-18-0131. 113 WAREHAMS POINT

JAMES CITY COUNTY CHESAPEAKE BAY PRESERVATION ORDINANCE EXCEPTION

WHEREAS, Miley and Jean Walker (the “Applicants”) have applied to the Chesapeake Bay Board of James City County (the “Board”) on September 12, 2018, to request an exception to use the Resource Protection Area (the “RPA”) on a parcel of property identified as James City County Real Estate Tax Parcel No. 5041900113 and further identified as 113 Warehams Point (the “Property”) as set forth in the application CBPA-18-0131 for the purpose of the construction of a retaining wall; and

WHEREAS, the Board has listened to the arguments presented and has carefully considered all evidence entered into the record.

NOW, THEREFORE, BE IT RESOLVED that the Chesapeake Bay Board of James City County, Virginia, following a public hearing, by a majority vote of its members FINDS that:

1. The exception request is the minimum necessary to afford relief.
2. Granting the exception will not confer upon the Applicants any special privileges denied by Chapter 23, Chesapeake Bay Preservation, of the James City County Code, to other property owners similarly situated in the vicinity.
3. The exception request will be in harmony with the purpose and intent of Chapter 23 of the James City County Code and is not of substantial detriment to water quality.
4. The exception request is not based on conditions or circumstances that are self-created or self-imposed, nor does the request arise from conditions or circumstances either permitted or non-conforming that are related to adjacent parcels.
5. Reasonable and appropriate conditions are hereby imposed, as set forth below, which will prevent the exception request from causing a degradation of water quality.
6. In granting this exception, the following conditions are hereby imposed to prevent this exception request from causing degradation of water quality:
 - a. The applicants must obtain all other necessary federal, state and local permits required for the project.
 - b. A surety of \$250 in a form acceptable to the James City County Attorney to ensure the mitigation.
 - c. This exception request approval shall become null and void if construction has not begun by September 12, 2019.

- d. Written requests for an extension to an exception shall be submitted to the Stormwater and Resource Protection Division no later than six weeks prior to the expiration date.

David Gussman
Chair, Chesapeake Bay Board

Michael D. Woolson
Secretary to the Board

Adopted by the Chesapeake Bay Board of James City County, Virginia, this 12th day of September, 2018.

THE FOREGOING INSTRUMENT WAS ACKNOWLEDGED BEFORE ME THIS ____ DAY OF _____, 20__ IN THE COMMONWEALTH OF VIRGINIA, IN THE COUNTY OF JAMES CITY.

NOTARY PUBLIC

MY COMMISSION EXPIRES: _____

CBPA18-0131WarehamsPt-res

ITEM SUMMARY

DATE: 9/12/2018
TO: Chesapeake Bay Board
FROM: Michael Woolson, Senior Watershed Planner
SUBJECT: CBPA 18-0149 : 213 Southpoint Drive

ATTACHMENTS:

	Description	Type
☐	Public Notice	Cover Memo
☐	APO Letter	Cover Memo
☐	APO Mailing List	Cover Memo
☐	Staff Report	Cover Memo
☐	Resolution	Cover Memo
☐	Site Plan	Cover Memo

REVIEWERS:

Department	Reviewer	Action	Date
Chesapeake Bay Group	Geissler, Fran	Approved	9/5/2018 - 4:00 PM
Chesapeake Bay Group	Geissler, Fran	Approved	9/5/2018 - 4:01 PM
Publication Management	Burcham, Nan	Approved	9/5/2018 - 4:07 PM
Chesapeake Bay Group	Secretary, ChesBay	Approved	9/6/2018 - 1:24 PM



PUBLIC HEARING NOTICE

THE WETLANDS AND CHESAPEAKE BAY BOARDS OF JAMES CITY COUNTY, VIRGINIA WILL HOLD A PUBLIC HEARING ON **WEDNESDAY, SEPTEMBER 12, 2018, AT 5 P.M.** IN THE BOARD ROOM OF BUILDING E, 101 MOUNTS BAY ROAD, JAMES CITY COUNTY, VIRGINIA.

THE WETLANDS BOARD WILL CONSIDER THE FOLLOWING CASE:

WJPA 18-0070/VMRC 17-0133: William & Mary Sailing Club has applied for a wetland permit to construct a floating dock at the Kingsmill Marina, 1010 Kingsmill Road in the Kingsmill on the James subdivision, JCC Parcel No. 5040100002C.

THE CHESAPEAKE BAY BOARD WILL CONSIDER THE FOLLOWING CASES:

CBPA 18-0129: Mr. Jeff Davis has filed an exception request for encroachment into the RPA buffer for the construction of a shed at 343 Neck-O-Land Road in the Berkeley District, JCC Parcel No. 4730100055.

CBPA 18-0134: Mr. and Mrs. N. Ross and Amy Thompson have filed an exception request for encroachment into the RPA buffer for the construction of a single family dwelling, deck, patio, retaining walls and a barn addition at 500 Thompson Lane in the Powhatan District, JCC Parcel No. 3610100005.

CBPA 18-0148: SeaWorld Parks and Entertainment has filed an exception request for encroachment into the RPA buffer for the construction of a new structure in the Festa Italia section of Busch Gardens Williamsburg at 7851 Pocahontas Trail, JCC Parcel No. 55140100009.

CBPA 18-0149: Ms. Meredith Robertson has filed an exception request for encroachment into the RPA buffer for the construction of two retaining walls at 213 Southpoint Drive in the Kingspoint subdivision, JCC Parcel No. 4930270014.

CBPA 18-0126: Mr. John Hyland has filed an exception request for encroachment into the RPA buffer for the construction of a detached workshop at 3936 Vass Lane in the Vass Meadows subdivision, JCC Parcel No. 3842100009.

CBPA 18-0131: Ms. Jean Walker has filed an exception request for encroachment into the RPA buffer for the construction of a retaining wall at 113 Wareham's Point in the Kingsmill on the James subdivision, JCC Parcel No. 5041900113.

Appeals from decisions under the Chesapeake Bay Preservation Ordinance may also be heard.

All interested parties are invited to attend the meetings. The applications and plans are on file and may be viewed during normal office hours in the Stormwater and Resource Protection Division, 101 Mounts Bay Road, Building E, James City County, Virginia.



General Services
Stormwater and Resource
Protection Division
101-E Mounts Bay Road
Williamsburg, VA 23185
757-253-6790

Resource.Protection@jamescitycountyva.gov

August 22, 2018

RE: CBPA-18-0149 – 213 Southpoint Drive
Two Retaining Walls

Dear Adjacent Property Owner:

In accordance with State and County Codes, this letter is to notify you that a request has been filed with the James City County Chesapeake Bay Board by Meredith Robertson for encroachment into the Resource Protection Area (RPA) buffer associated with construction of two retaining walls. The project is located at 213 Southpoint Drive in the Kingspoint subdivision located in James City County. The property is further identified by James City County Real Estate as Pin No. 4930270014.

A complete description, plan, and other information are on file in the Stormwater and Resource Protection Division and are available for inspection during normal business hours, should anyone desire to review them.

The Chesapeake Bay Board will hold an advertised public hearing on **Wednesday, September 12, 2018 at 5:00 p.m.**, in the Board Room of Building F, 101-F, Mounts Bay Road, James City County, Virginia, at which time you may request to speak on the above referenced project.

Sincerely,

Janice Petty

Janice Petty
Stormwater Assistant

cc: Applicant /Owner
The Structures Group/Contractor

Mailing List for: CBPA-18-0149 – 213 Southpoint Drive – Robertson – Two Retaining Walls

Owner: 4930270014

Robertson, Christopher S & Meredith
213 Southpoint Drive
Williamsburg, VA 23185-4439

The Structures Group
Attn: Kyle J. Polk
1200 Old Colony Lane
Williamsburg, VA 23185

4930280004

Pratt, Donald I, Jr, Trustee & Gerald
110 Archers Hope Drive
Williamsburg, VA 23185-4406

4930280003

Young, Pamela J
108 Archers Hope Drive
Williamsburg, VA 23185-4406

4930270013

Koch, Denise W, Trustee
215 Southpoint Drive
Williamsburg, VA 23185-4439

4930270005

Lerberg, Scott B & Elizabeth Joy Waterson
212 Southpoint Drive
Williamsburg, VA 23185-4440

4930300001

Robinson, Millard P, Jr. & Mireille A
6401 Conservancy
Williamsburg, VA 23185-8068

4930300002

Sweaney, Robert D & Teresa C
6405 Conservancy
Williamsburg, VA 23185-8068

**CHESAPEAKE BAY BOARD EXCEPTION No. CBPA-18-0149. 213 Southpoint Drive
Staff Report for the September 12, 2018, Chesapeake Bay Board Public Hearing**

This staff report is prepared by James City County Stormwater and Resource Protection to provide information to the Chesapeake Bay Board to assist them in making a recommendation on this assessment. It may be useful to members of the general public interested in this assessment.

EXISTING SITE DATA AND INFORMATION

Applicant: Ms. Meredith Robertson

Agent: Mr. Michael Mathews

Location: 213 Southpoint Drive

Tax Map/Parcel No.: 4930270014

Parcel: Kingspoint, Lot 14, Section 7

Lot Size: 2.36 acres

Area of Lot in Resource Protection Area (RPA): 1.85 acres +/- (78%)

Watershed: College Creek, (HUC JL34)

Floodplain: Coastal Zone AE and Zone AE - base flood elevation determined to be 8 feet mean sea level

Proposed Activity: Construction of retaining walls

Impervious Cover: 186 square feet

RPA Encroachment: 4,500 square feet, seaward 50-foot RPA buffer

Staff Contact: Trevor Long, Watershed Planner Phone: 253-6789

BRIEF SUMMARY AND DESCRIPTION OF ACTIVITIES

Mr. Michael Mathews has applied for a Chesapeake Bay Exception on behalf of Ms. Meredith Robertson for encroachments into the RPA buffer for the construction of retaining walls on property located at 213 Southpoint Drive within the College Creek watershed. The property is further identified as James City County Tax Map Parcel No. 4930270014. The parcel was platted in 1973, prior to the adoption of the Chesapeake Bay Preservation Ordinance in 1990.

Steep slopes encompass the rear portion of the property near the house, with erosion occurring near the edge of slope. For this reason, the applicant has proposed a retaining wall to control erosion and make for safer walking conditions in the backyard. RPA encroachments for the proposed retaining wall equate to 186 square feet of impervious surface. Required plantings for this amount of encroachment would be one tree and three native shrubs. The applicant has proposed the plantings of 18 native shrubs, therefore the proposed mitigation exceeds County requirements.

STAFF EVALUATION

Staff has evaluated the application and exception request for the construction of the shed and finds that the application meets the conditions in Sections 23-11 and 23-14 and that the application should be heard by the Board because the retaining wall is accessory in nature. Therefore, this request must be considered by the Board following a public hearing under the formal exception process. Per Sections 23-11 and 23-14 of the County Ordinance, a Water Quality Impact Assessment (WQIA) was submitted for the proposed project.

CONSIDERATION BY THE CHESAPEAKE BAY BOARD

The exception granting body is permitted to require reasonable and appropriate conditions in granting the exception request in accordance with Section 23-14. The Chesapeake Bay Board should fully consider Chesapeake Bay Exception CBPA-18-0149 as outlined and presented above and review the request for exception along with the WQIA. The Board may grant the exception with such conditions and safeguards as deemed necessary to further the purpose and intent of the County's Chesapeake Bay Preservation Ordinance.

STAFF RECOMMENDATIONS

Staff has reviewed the application and exception request and has determined impacts associated with the proposal to be minor for the proposed development. Staff recommends approval of this exception request with the following conditions incorporated into the approval:

1. The applicant must obtain all other necessary federal, state and local permits as required for the project.
2. All development activities located in the special flood hazard area shall comply with Article VI, Division 3, Floodplain Area Regulations of the James City County Zoning Ordinance and receive all required approvals and permits prior to commencement of such activities.
3. A mitigation plan consistent with County requirements be submitted along with a surety of \$500 in a form acceptable to the James City County Attorney to ensure the mitigation.
4. This exception request approval shall become null and void if construction has not begun by September 12, 2019.
5. Written requests for an extension to an exception shall be submitted to the Stormwater and Resource Protection Division no later than six weeks prior to the expiration date.

TL/nb
CBPA18-149-213SthpntDr

Attachments:

1. Resolution
2. Water Quality Impact Assessment Package
3. Site Plan

RESOLUTION

CASE NO. CBPA-18-0149. 213 SOUTHPOINT DRIVE

JAMES CITY COUNTY CHESAPEAKE BAY PRESERVATION ORDINANCE EXCEPTION

WHEREAS, Ms. Meredith Robertson (the “Applicant”) has applied to the Chesapeake Bay Board of James City County (the “Board”) on September 12, 2018, to request an exception to use the Resource Protection Area (the “RPA”) on a parcel of property identified as James City County Real Estate Tax Parcel No. 4930270014 and further identified as 213 Southpoint Drive (the “Property”) as set forth in the application CBPA-18-0149 for the purpose of constructing retaining walls; and

WHEREAS, the Board has listened to the arguments presented and has carefully considered all evidence entered into the record.

NOW, THEREFORE, BE IT RESOLVED that the Chesapeake Bay Board of James City County, Virginia, following a public hearing, by a majority vote of its members FINDS that:

1. The exception request is the minimum necessary to afford relief.
2. Granting the exception will not confer upon the Applicant any special privileges denied by Chapter 23, Chesapeake Bay Preservation, of the James City County Code, to other property owners similarly situated in the vicinity.
3. The exception request will be in harmony with the purpose and intent of Chapter 23 of the James City County Code and is not of substantial detriment to water quality.
4. The exception request is not based on conditions or circumstances that are self-created or self-imposed, nor does the request arise from conditions or circumstances either permitted or non-conforming that are related to adjacent parcels.
5. Reasonable and appropriate conditions are hereby imposed, as set forth below, which will prevent the exception request from causing a degradation of water quality.
6. In granting this exception, the following conditions are hereby imposed to prevent this exception request from causing degradation of water quality:
 - a. The applicant must obtain all other necessary federal, state and local permits required for the project.
 - b. All development activities located in the special flood hazard area shall comply with Article VI, Division 3, Floodplain Area Regulations of the James City County Zoning Ordinance and receive all required approvals and permits prior to commencement of such activities.

- c. A mitigation plan congruent with County requirements shall be submitted along with a surety of \$500 in a form acceptable to the James City County Attorney to ensure the mitigation.
- d. This exception request approval shall become null and void if construction has not begun by September 12, 2019.
- e. Written requests for an extension to an exception shall be submitted to the Stormwater and Resource Protection Division no later than six weeks prior to the expiration date.

 David Gussman
 Chair, Chesapeake Bay Board

 Michael D. Woolson
 Senior Watershed Planner

Adopted by the Chesapeake Bay Board of James City County, Virginia, this 12th day of September, 2018.

THE FOREGOING INSTRUMENT WAS ACKNOWLEDGED BEFORE ME THIS ____ DAY OF _____, 20__ IN THE COMMONWEALTH OF VIRGINIA, IN THE COUNTY OF JAMES CITY.

 NOTARY PUBLIC

MY COMMISSION EXPIRES: _____

CBPA18-149-213SthpntDr-res

EROSION & SEDIMENT CONTROL NOTES

GENERAL:

- THE PROFESSIONAL ENGINEER WHOSE SEAL IS AFFIXED HEREON SHALL ACT AS THE "RESPONSIBLE LAND DISTURBER" FOR THE PLAN AND FOR THIS PROJECT. ONCE THE PLANS ARE APPROVED, THE OWNER/GENERAL CONTRACTOR SHALL DESIGNATE THE "RESPONSIBLE LAND DISTURBER" AND PROVIDE THE COUNTY WITH THE NAME AND CERTIFICATION NO. OF THE "RESPONSIBLE LAND DISTURBER" FOR THE CONSTRUCTION PHASE OF THE PROJECT.
- THIS SITE IS LOCATED WITHIN THE CHESAPEAKE BAY WATERSHED. THE PROJECT AREA IS LOCATED WITHIN THE LIMITS OF THE CHESAPEAKE BAY PRESERVATION ACT RPA/RMA AREAS.
- ELEVATIONS SHOWN ARE APPROXIMATE, AND ARE BASED ON TOPOGRAPHIC MAP PROVIDED BY THE JAMES CITY COUNTY GEOGRAPHICAL INFORMATION SYSTEM (GIS).
- THE EXISTENCE AND LOCATION (HORIZONTAL AND VERTICAL) OF EXISTING UTILITIES ARE NOT GUARANTEED AND SHALL BE FIELD VERIFIED BY THE CONTRACTOR.
- THERE ARE NO ANTICIPATED OFFSITE LAND DISTURBING AREAS ASSOCIATED WITH THE DEVELOPMENT OF THIS SITE.
- A LAND DISTURBING PERMIT IS NOT REQUIRED FOR SINGLE-FAMILY RESIDENCE PROJECTS INCLUDING ALL AREAS SUBJECT TO THE CHESAPEAKE BAY PRESERVATION ACT.
- ALL OBJECTIONABLE AND DELETERIOUS MATERIAL IS TO BE REMOVED FROM THE SITE AND DISPOSED OF IN A STATE APPROVED FACILITY MEETING ALL REQUIREMENTS OF ALL LOCAL, STATE, AND FEDERAL REGULATIONS.
- DURING CONSTRUCTION OF THE PROJECT, SOIL STOCKPILES AND BORROW AREAS SHALL BE STABILIZED OR PROTECTED WITH SEDIMENT TRAPPING MEASURES. THE CONTRACTOR IS RESPONSIBLE FOR THE TEMPORARY PROTECTION AND PERMANENT STABILIZATION OF ALL SOIL STOCKPILES ON SITE AS WELL AS BORROW AREAS AND SOIL INTENTIONALLY TRANSPORTED FROM THE SITE.
- ALL AREAS DISTURBED BY CONSTRUCTION SHALL BE STABILIZED WITH PERMANENT SEEDING IMMEDIATELY FOLLOWING FINISH GRADING. SEEDING SHALL BE DONE WITH THE MINIMUM CARE LAWN BLEND ACCORDING TO TABLE 3.32-2 OF STANDARD AND SPECIFICATION 3.32. "PERMANENT SEEDING" OF THE VESCH. EROSION BLANKETS WILL BE INSTALLED OVER FILL SLOPES WHICH HAVE BEEN BROUGHT TO FINAL GRADE AND HAVE BEEN SEEDING TO PROTECT THE SLOPES FROM RILL AND GULLY EROSION TO ALLOW THE SEED TO GERMINATE PROPERLY. MULCH (STRAW OR FIBER) WILL BE USED ON RELATIVELY FLAT AREAS. IN ALL SEEDING OPERATIONS, SEED, FERTILIZER, AND LIME WILL BE APPLIED PRIOR TO MULCHING. SOIL STABILIZATION MATTING TO BE VESCH TYPICAL TREATMENT T-1 (JUTE MESH).

JAMES CITY COUNTY STANDARD STORMWATER POLLUTION PREVENTION PLAN NOTES:

THE FOLLOWING STANDARD COUNTY NOTES SHALL BECOME PART OF ANY APPROVED STORMWATER POLLUTION PREVENTION PLAN (SWPPP) FOR PLAN OF DEVELOPMENT PROJECTS IN JAMES CITY COUNTY, VIRGINIA. COMPONENTS OF A SWPPP MAY INCLUDE AS APPLICABLE, A SITE EROSION AND SEDIMENT CONTROL (EISC) PLAN, A SITE STORMWATER MANAGEMENT (SSM) PLAN, AND A SITE POLLUTION PREVENTION PLAN (PPP). THE COUNTY'S DIVISION OF ENGINEERING AND RESOURCE PROTECTION IS DESIGNATED BY CHAPTER 8 OF THE COUNTY CODE AS THE LOCAL VIRGINIA EROSION AND SEDIMENT CONTROL PROGRAM (VESCP) AUTHORITY AND VIRGINIA STORMWATER MANAGEMENT PROGRAM (VSM) AUTHORITY.

- ALL THE PROVISIONS OF VIRGINIA EROSION AND SEDIMENT CONTROL (EISC) LAW AND REGULATIONS, THE VIRGINIA STORMWATER MANAGEMENT ACT AND REGULATIONS (VSM), THE VIRGINIA BMP CLEARINGHOUSE WEBSITE, STATE EROSION AND SEDIMENT CONTROL AND STORMWATER MANAGEMENT HANDBOOKS, AND ANY ASSOCIATED TECHNICAL BULLETINS AND GUIDANCE DOCUMENTS AS PUBLISHED BY THE STATE WATER CONTROL BOARD, THE VIRGINIA DEPARTMENT OF ENVIRONMENTAL QUALITY (DEQ), AND THE LOCAL VESCP AND VSM AUTHORITY SHALL APPLY TO THE PROJECT.
- MINIMUM STANDARDS NO. 1 THROUGH NO. 14 OF THE VIRGINIA EROSION AND SEDIMENT CONTROL REGULATIONS 9VAC25-840 ET SEQ. SHALL APPLY TO THE PROJECT.
- THE OWNER, APPLICANT, OPERATOR, OR PERMITTEE SHALL BE RESPONSIBLE TO REGISTER FOR CONSTRUCTION GENERAL PERMIT (CGP) COVERAGE, AS APPLICABLE, IN ACCORDANCE WITH THE GENERAL VPDES PERMIT FOR DISCHARGE OF STORMWATER FROM CONSTRUCTION ACTIVITIES (VARIO) CHAPTER 800, THE VIRGINIA STORMWATER MANAGEMENT PROGRAM REGULATIONS CHAPTER 810; AND IN ACCORDANCE WITH CURRENT REQUIREMENTS OF THE VIRGINIA STORMWATER MANAGEMENT PROGRAM (VSM), THE STATE WATER CONTROL BOARD, THE VIRGINIA DEPARTMENT OF ENVIRONMENTAL QUALITY, CHAPTER 8 OF THE COUNTY CODE AND THE LOCAL VESCP/VSM AUTHORITY.
- THE OWNER, APPLICANT, OPERATOR OR PERMITTEE SHALL PROVIDE THE NAME OF AN INDIVIDUAL HOLDING A VALID RESPONSIBLE LAND DISTURBER (RLD) CERTIFICATE OF COMPETENCE WHO WILL BE RESPONSIBLE FOR THE LAND DISTURBING ACTIVITY PRIOR TO ENGAGING IN THE LAND DISTURBING ACTIVITY. THIS WILL BE NECESSARY PRIOR TO ISSUANCE OF A LOCAL LAND DISTURBING AND/OR STORMWATER CONSTRUCTION PERMIT FOR THE PROJECT. THE RLD IS REQUIRED TO ATTEND THE PRECONSTRUCTION CONFERENCE FOR THE PROJECT.
- THE CONTRACTOR IS RESPONSIBLE TO CONTACT MISS UTILITY (DIAL 811 IN VA OR 1-800-552-7001) PRIOR TO ANY UTILITY OR SITE WORK EXCAVATIONS.
- ALL EROSION AND SEDIMENT CONTROL MEASURES SHALL BE PLANNED, DESIGNED, IMPLEMENTED, INSTALLED AND MAINTAINED IN ACCORDANCE WITH THE PROVISIONS OF THE LATEST EDITION OF THE VIRGINIA EROSION AND SEDIMENT CONTROL HANDBOOK (VESCH). THE CONTRACTOR SHALL MAINTAIN, INSPECT, AND REPAIR ALL EROSION AND SEDIMENT CONTROL MEASURES AS NEEDED THROUGHOUT THE LIFE OF THE PROJECT TO ENSURE CONTINUED ACCEPTABLE PERFORMANCE.
- A PRECONSTRUCTION CONFERENCE (MEETING) SHALL BE HELD ON SITE AND INCLUDE REPRESENTATIVES FROM THE LOCAL VESCP/VSM AUTHORITY, THE OWNER/APPLICANT/OPERATOR/PERMITTEE, THE RESPONSIBLE LAND-DISTURBER (RLD), AND THE CONTRACTOR, ENGINEER, AND OTHER RESPONSIBLE AGENCIES, AS APPLICABLE, PRIOR TO AUTHORIZATION AND ISSUANCE OF A LOCAL LAND DISTURBING OR STORMWATER CONSTRUCTION PERMIT. THE OWNER, APPLICANT, OPERATOR OR PERMITTEE IS REQUIRED TO COORDINATE SCHEDULING OF THE PRECONSTRUCTION CONFERENCE BETWEEN ALL APPLICABLE PARTIES. THE CONTRACTOR SHALL SUBMIT A SEQUENCE OF CONSTRUCTION AND A REVISED POLLUTION PREVENTION PLAN (P2 PLAN OR PPP), IF APPLICABLE, TO THE LOCAL VESCP/VSM AUTHORITY FOR REVIEW AND APPROVAL PRIOR TO THE PRECONSTRUCTION MEETING.
- A POLLUTION PREVENTION PLAN (P2 PLAN OR PPP), IF REQUIRED, SHALL BE DEVELOPED, IMPLEMENTED AND UPDATED AS NECESSARY AND MUST DETAIL THE DESIGN, INSTALLATION, IMPLEMENTATION AND MAINTENANCE OF EFFECTIVE POLLUTION PREVENTION MEASURES TO: MINIMIZE THE DISCHARGE OF POLLUTANTS FROM EQUIPMENT AND VEHICLE WASHING, WHEEL WASH WATER AND OTHER WASH WATERS; MINIMIZE THE EXPOSURE OF ALL MATERIALS ON THE SITE (SUCH AS BUILDING MATERIALS AND PRODUCTS, CONSTRUCTION WASTE, TRASH, LANDSCAPE MATERIALS, FERTILIZERS, PESTICIDES, HERBICIDES, DETERGENTS, SANITARY WASTE, ETC.) TO PRECIPITATION AND STORMWATER; MINIMIZE THE DISCHARGE OF POLLUTANTS FROM SPILLS AND LEAKS; IMPLEMENT CHEMICAL SPILL AND LEAK PREVENTION AND RESPONSE PROCEDURES; AND INCLUDE EFFECTIVE BEST MANAGEMENT PRACTICES TO PROHIBIT THE DISCHARGE OF WASTEWATER FROM CONCRETE WASHOUT AREAS, DISCHARGE OF WASTEWATER FROM WASHOUT AND CLEANOUT OF STUCCO, PAINT, FORM RELEASE OILS, CURING COMPOUNDS AND OTHER CONSTRUCTION MATERIALS; DISCHARGE OF FUELS, OILS, OTHER POLLUTANTS USED IN VEHICLE AND EQUIPMENT OPERATION AND MAINTENANCE ACTIVITIES; AND THE DISCHARGE OF SOAPS AND SOLVENTS USED FOR VEHICLE AND EQUIPMENT WASHING. THIS PLAN SHALL BE AVAILABLE ONSITE FOR REVIEW AT REASONABLE TIMES BY THE LOCAL VESCP/VSM AUTHORITY WHEN REQUESTED.
- THE OWNER, APPLICANT, OPERATOR, OR PERMITTEE IS RESPONSIBLE FOR ALL OPERATOR SELF-INSPECTIONS AS REQUIRED IN THE POLLUTION PREVENTION PLAN (P2 PLAN OR PPP) OR AS REQUIRED AS PART OF A DEVELOPED STORMWATER POLLUTION PREVENTION PLAN (SWPPP). THESE INSPECTIONS SHALL BE MADE AVAILABLE, UPON REQUEST, BY THE LOCAL VESCP/VSM AUTHORITY.
- ALL PERIMETER EROSION AND SEDIMENT CONTROL (EISC) MEASURES SHALL BE CONSTRUCTED AS A FIRST STEP IN ANY LAND-DISTURBING ACTIVITY AND SHALL BE MADE FUNCTIONAL BEFORE UPSLOPE LAND DISTURBANCE ACTIVITY TAKES PLACE.
- ADDITIONAL SAFETY FENCE OR DUST CONTROL MEASURES, IN ACCORDANCE WITH THE PROVISIONS OF MINIMUM STANDARDS & SPECS. 3.01 AND 3.04 OF THE VIRGINIA EROSION AND SEDIMENT CONTROL HANDBOOK (VESCH), MAY BE REQUIRED TO BE IMPLEMENTED ON THE SITE IN ADDITION TO THAT SHOWN ON THE APPROVED PLAN AND SPECIFICATIONS IN ORDER TO ENSURE ADEQUATE PROTECTION OF THE HEALTH, SAFETY AND WELFARE OF THE PUBLIC OR IF SITE CONDITIONS CHANGE, BECOME APPARENT OR ALTER SIGNIFICANTLY FOLLOWING THE DATE OF PLAN APPROVAL.

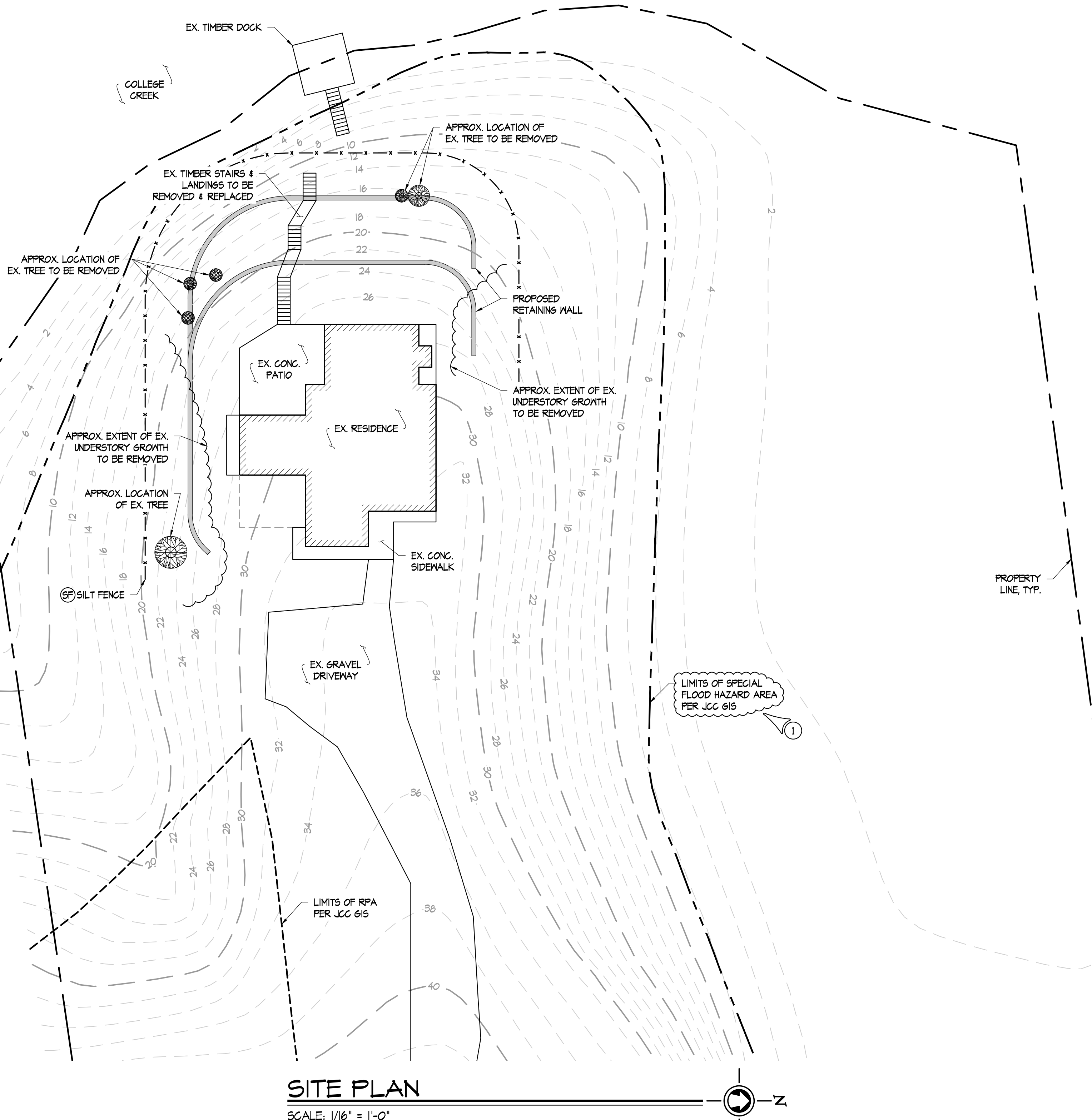

SITE PLAN

SCALE: 1/16" = 1'-0"

STATISTICAL INFORMATION

ZONE:	RI - LIMITED RESIDENTIAL		
PARCEL ID NO.:	4930210014		
OWNER:	ROBERTSON, MEREDITH		
SITE DESCRIPTION:	KINGSPOINT, SECTION-1, LOT-14		
PROJECT AREA:	4,126 SQ. FT (0.11 ACRES)		
IMPERVIOUS COVER FOR PROJECT AREA:			
	PRE-CONSTRUCTION POST-CONSTRUCTION NET CHANGE		
GREEN AREA	4,519 SQ. FT (47%)	4,342 SQ. FT (43%)	-176 SQ. FT (4%)
IMPERVIOUS AREA	149 SQ. FT (3%)	394 SQ. FT (7%)	+145 SQ. FT (4%)
TOTAL AREA	4,126 SQ. FT (100%)	4,126 SQ. FT (100%)	0 SQ. FT (0%)
LIMITS OF DISTURBANCE:			
	RETAINING WALLS	244 SQ. FT	
	PLANTING/GRADING AREA	4,482 SQ. FT	
	TOTAL AREA	4,126 SQ. FT	

LEGEND			
MARK	SYMBOL	CODE	DESCRIPTION
—x—x—	⊗	3.01	SILT FENCE

JAMES CITY COUNTY STANDARD STORMWATER POLLUTION PREVENTION PLAN NOTES (CONT.):

- EROSION AND SEDIMENT CONTROL MEASURES MAY REQUIRE MINOR FIELD ADJUSTMENTS AT OR FOLLOWING TIME OF CONSTRUCTION TO ENSURE THEIR INTENDED PURPOSE IS ACCOMPLISHED. TO ENSURE ADEQUATE PROTECTION OF THE HEALTH, SAFETY, AND WELFARE OF THE PUBLIC, OR IF SITE CONDITIONS CHANGE, BECOME APPARENT OR ALTER SIGNIFICANTLY FOLLOWING THE DATE OF PLAN APPROVAL. LOCAL VESCP/VSM AUTHORITY APPROVAL SHALL BE REQUIRED FOR ANY DEVIATION OF EROSION AND SEDIMENT CONTROL MEASURES FROM THE APPROVED PLAN.
- OFF-SITE WASTE OR BORROW AREAS SHALL BE APPROVED BY THE LOCAL VESCP/VSM AUTHORITY PRIOR TO THE IMPORT OF ANY BORROW OR EXPORT OF ANY WASTE TO OR FROM THE PROJECT SITE.
- TEMPORARY SOIL STOCKPILES SHALL COMPLY WITH THE PROVISIONS OF SECTION 24-46 OF THE COUNTY CODE.
- CULVERT AND STORM DRAIN INLET PROTECTIONS, IN ACCORDANCE WITH THE PROVISIONS OF MINIMUM STANDARDS & SPECS. 3.01 AND 3.08 OF THE VIRGINIA EROSION AND SEDIMENT CONTROL HANDBOOK (VESCH), MAY BE REMOVED AT THE DISCRETION OF THE ASSIGNED LOCAL VESCP/VSM AUTHORITY COMPLIANCE INSPECTOR, SHOULD PLACEMENT OF THE MEASURE RESULT IN EXCESSIVE ROAD FLOODING, TRAFFIC OR SAFETY HAZARD, OR RESULT IN THE REDIRECTION OF DRAINAGE ONTO OR TOWARD EXISTING LOTS, HOMES, DRIVEWAYS, GARAGES OR OTHER STRUCTURES. DECISIONS SHALL BE MADE BY THE VESCP/VSM AUTHORITY ON A CASE-BY-CASE BASIS BASED ON FIELD SITUATIONS ENCOUNTERED.
- DRAINAGE FACILITIES SHALL BE INSTALLED AND FUNCTIONAL WITHIN 30 DAYS FOLLOWING COMPLETION OF ROUGH GRADING AT ANY POINT WITHIN THE PROJECT.
- NO MORE THAN 300 FEET OF TRENCH MAY BE OPEN AT ONE TIME FOR UNDERGROUND UTILITY LINES, INCLUDING STORM WATER CONVEYANCES. ALL OTHER PROVISIONS OF MINIMUM STANDARD NO. 16 OF THE VIRGINIA EROSION AND SEDIMENT CONTROL REGULATIONS APPLY.
- PERMANENT OR TEMPORARY STABILIZATION OF DISTURBED SOIL AREAS SHALL COMPLY WITH MINIMUM STANDARD # 1 AND # 3 OF THE VIRGINIA EROSION AND SEDIMENT CONTROL REGULATIONS.
- THE TERM SEEDING, FINAL VEGETATIVE COVER OR STABILIZATION ON THE APPROVED PLAN SHALL MEAN THE SUCCESSFUL GERMINATION AND ESTABLISHMENT OF A STABLE GRASS COVER FROM A PROPERLY PREPARED SEEDBED, IN ACCORDANCE WITH MINIMUM STANDARD # 1 AND # 3 FROM THE VIRGINIA EROSION AND SEDIMENT CONTROL REGULATIONS, MINIMUM STANDARDS & SPECS. 3.24 THROUGH 3.31 OF THE VIRGINIA EROSION AND SEDIMENT CONTROL HANDBOOK (VESCH), AND ANY TECHNICAL BULLETINS ISSUED BY THE STATE WATER CONTROL BOARD OR VIRGINIA DEQ, AS APPLICABLE. IRRIGATION, IF NECESSARY, SHALL COMPLY WITH ALL APPLICABLE SEASONAL OUTDOOR WATER USE RESTRICTIONS OF THE JAMES CITY SERVICE AUTHORITY.
- IF DISTURBED AREA STABILIZATION IS TO BE ACCOMPLISHED DURING THE MONTHS OF DECEMBER, JANUARY OR FEBRUARY, STABILIZATION SHALL CONSIST OF MULCHING IN ACCORDANCE WITH MINIMUM STANDARD & SPEC. 3.35 OF THE VIRGINIA EROSION AND SEDIMENT CONTROL HANDBOOK (VESCH). SEEDING WILL THEN TAKE PLACE AS SOON AS THE SEASON PERMITS.
- TEMPORARY EROSION AND SEDIMENT CONTROL MEASURES SHALL NOT BE REMOVED UNTIL ALL DISTURBED AREAS ARE STABILIZED. REMOVAL SHALL NOT OCCUR WITHOUT AUTHORIZATION BY THE LOCAL VESCP/VSM AUTHORITY. DISTURBANCES ASSOCIATED WITH THE REMOVAL OF TEMPORARY EROSION AND SEDIMENT CONTROL MEASURES SHALL BE PROPERLY STABILIZED.
- NO SEDIMENT TRAP OR SEDIMENT BASIN SHALL BE REMOVED UNTIL A) AT LEAST 75 PERCENT OF THE SINGLE-FAMILY LOTS WITHIN THE DRAINAGE AREA TO THE TRAP OR BASIN HAVE BEEN SOLD TO A THIRD PARTY FOR THE CONSTRUCTION OF HOMES (UNRELATED TO THE DEVELOPER); AND/OR B) 60 PERCENT OF THE SINGLE-FAMILY LOTS WITHIN THE DRAINAGE AREA TO THE TRAP OR BASIN ARE COMPLETED AND STABILIZED. A BULK SALE OF THE LOTS TO ANOTHER BUILDER DOES NOT SATISFY THIS PROVISION. SEDIMENT TRAPS AND SEDIMENT BASINS SHALL NOT BE REMOVED WITHOUT AUTHORIZATION OF THE LOCAL VESCP/VSM AUTHORITY.
- DESIGN AND CONSTRUCTION OF PRIVATE-TYPE STORM DRAINAGE SYSTEMS, OUTSIDE VDOT RIGHT-OF-WAY, SHALL BE PERFORMED IN ACCORDANCE WITH THE CURRENT VERSION OF THE JAMES CITY COUNTY, ENGINEERING AND RESOURCE PROTECTION DIVISION, STORMWATER DRAINAGE CONVEYANCE SYSTEMS (NON-BMP RELATED), GENERAL DESIGN AND CONSTRUCTION GUIDELINES (IE. COUNTY DRAINAGE STANDARDS).
- RECORD DRAWINGS (ASBUILTS) AND CONSTRUCTION CERTIFICATIONS ARE REQUIRED FOR ALL STORMWATER FACILITIES INCLUDING STORMWATER MANAGEMENT/BMP FACILITIES AND STORM DRAINAGE CONVEYANCE SYSTEMS. THE CERTIFICATION PROCESS SHALL INCLUDE AN INTERNAL CLOSED-CIRCUIT TELEVISION CAMERA (CCTV) POST INSTALLATION INSPECTION PERFORMED BY THE OWNER IN ACCORDANCE WITH STANDARDS AND SPECIFICATIONS DEVELOPED BY THE VSM AUTHORITY. RECORD DRAWINGS AND CONSTRUCTION CERTIFICATIONS MUST MEET ESTABLISHED PROGRAM REQUIREMENTS OF THE COUNTY'S CHAPTER 8 EROSION AND SEDIMENT CONTROL AND VSM ORDINANCE AND THE LOCAL VESCP/VSM AUTHORITY.
- ALL STORMWATER FACILITIES INCLUDING BMPs, STORM DRAINAGE PIPES, STORMWATER CONVEYANCES, INLETS, MANHOLES, OUTFALLS AND ROADSIDE AND OTHER OPEN CHANNELS SHALL BE INSPECTED BY THE LOCAL VESCP/VSM AUTHORITY, THE OWNER, AND THE APPLICANT/OPERATOR/PERMITTEE DESIGNATED GEOTECHNICAL ENGINEER FOR THE PROJECT IN ACCORDANCE WITH ESTABLISHED COUNTY STORMWATER FACILITY INSPECTION PROGRAM REQUIREMENTS.

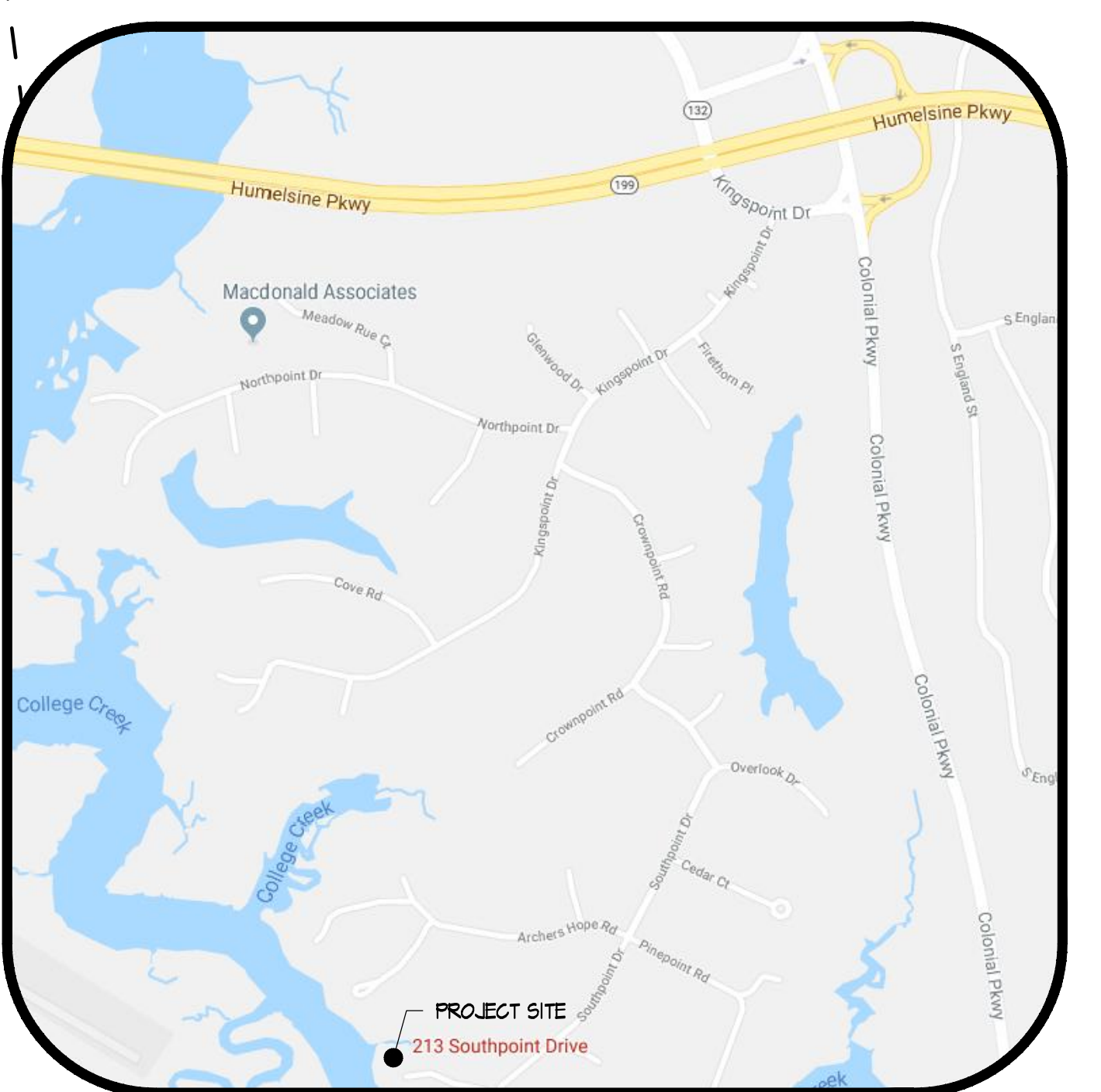

VICINITY MAP

SCALE: NONE

Sheet: **61** | of 3

EROSION & SEDIMENT CONTROL NOTES, SITE PLAN, VICINITY MAP, & STATISTICAL INFORMATION

RETAINING WALLS FOR ROBERTSON RESIDENCE 213 SOUTHPOINT DRIVE

JAMES CITY COUNTY VA

Project #: VA090905

Drawn by: KJP

Reviewed by: MAM

Date: 8/11/18

Professional Seal: MICHAEL A. MATTHEWS, License No. 01763, State of Virginia, Professional Engineer, 8/11/18

The Structures Group, Inc. 1200 Old Colony Lane • Williamsburg, VA 23185 (757) 220-0465 • Fax: (757) 220-1546 www.thestructuresgroup.com

Zoning: Plan Review Comments

Revisions: 9/4/18

GENERAL NOTES

- WORK PERFORMED SHALL COMPLY WITH THE FOLLOWING:
 - THE VIRGINIA UNIFORM STATEWIDE BUILDING CODE (VUBC); 2012 EDITION
 - THE INTERNATIONAL RESIDENTIAL CODE (IRC); 2012 EDITION AS AMENDED BY THE VUBC.
 - ALL APPLICABLE STATE AND LOCAL CODES, ORDINANCES AND REGULATIONS.
 - DESIGN LOADS:

A. BUILDING CLASSIFICATION CATEGORY	
B. GROUND SNOW, P _g	20 PSF
C. ULTIMATE WIND SPEED	105 MPH
EXPOSURE	B
D. SOIL UNIT WEIGHT	120 PCF
E. LIVE LOADS:	
LANDSCAPE & MAINTENANCE	UNIFORM 50 PSF
 - THE CONTRACTOR SHALL VERIFY DIMENSIONS IN FIELD PRIOR TO FABRICATION OF MEMBERS AND COMMENCING WORK.
 - CONTRACTOR SHALL NOTIFY "MISS UTILITY OF VIRGINIA" PRIOR TO BEGINNING EXCAVATION FOR LOCATION OF UNDERGROUND UTILITIES. THE CONTRACTOR SHALL BEAR SOLE RESPONSIBILITY FOR COSTS ASSOCIATED WITH DAMAGE AND REPAIR OF ANY LINES MARKED BY MISS UTILITY OF VIRGINIA.
 - PROVIDE TEMPORARY BRACING AS REQUIRED TO RESIST SOIL PRESSURE AND OTHER LOADS DURING CONSTRUCTION.
 - THE CONTRACTOR SHALL PROTECT EXISTING STRUCTURES, EQUIPMENT, ADJACENT GROUNDS, SPRINKLERS, TREES AND PLANTS DURING ALL PHASES OF CONSTRUCTION. THE CONTRACTOR SHALL REPAIR AND/OR REPLACE, AT NO ADDITIONAL COSTS TO THE OWNER, ANY ITEMS DAMAGED DURING THE CONSTRUCTION.
- LEVELING PAD:**
- LEVELING PAD FOR SEGMENTAL BLOCK RETAINING WALLS SHALL BE A MINIMUM OF 8" THICK 350 PSI FLOWABLE FILL. ALTERNATELY, COMPACTED NO. 21A CRUSHED STONE WRAPPED IN FILTER CLOTH MAY BE UTILIZED FOR THE LEVELING PAD.
 - ALL FLOWABLE FILL SHALL BE MIXED, PLACED AND TESTED IN ACCORDANCE WITH THE LATEST EDITION OF ACI 318.
 - ALL FLOWABLE FILL SHALL HAVE A SLUMP OF T ± 1" UNLESS NOTED OTHERWISE.
 - ALL FLOWABLE FILL TO BE POURED IN COLD WEATHER, AS DEFINED IN SECTION 1.1 OF ACI 306R, COLD WEATHER CONCRETING, SHALL FULLY COMPLY WITH ACI 306.1, STANDARD SPECIFICATIONS FOR COLD WEATHER CONCRETING, AND 306R.
 - ALL FLOWABLE FILL TO BE POURED IN HOT WEATHER, AS DEFINED IN SECTION 1.2 OF ACI 305R, HOT WEATHER CONCRETING, SHALL FULLY COMPLY WITH ACI 305.1, STANDARD SPECIFICATIONS FOR HOT WEATHER CONCRETING, AND ACI 305R.
- RETAINING WALL:**
- ELEVATIONS SHOWN ARE APPROXIMATE, AND ARE BASED ON TOPOGRAPHIC MAP PROVIDED BY THE JAMES CITY COUNTY GEOGRAPHICAL INFORMATION SYSTEM (GIS).
 - EXISTING SITE SOILS ARE EMPORIA COMPLEX WITH MODERATE SHRINK-SWELL POTENTIAL BASED ON THE USDA SOIL SURVEY.
 - LEVELING PAD WAS DESIGNED TO BEAR ON UNDISTURBED SOIL, A MINIMUM OF 1'-4" BELOW THE EXISTING GRADE UNLESS NOTED OTHERWISE WITH A MINIMUM SOIL BEARING PRESSURE OF 2,000 PSF UNLESS NOTED OTHERWISE.
 - BACKFILL MATERIAL MUST BE COMPACTED TO 95% STANDARD PROCTOR DENSITY IN MAXIMUM 8" LIFTS USING A VIBRATORY PLATE COMPACTOR. ALL BACKFILL SHALL BE FREE-DRAINING, NON-FROST SUSCEPTIBLE GRANULAR MATERIAL 5M OR BETTER UNLESS NOTED TO BE STONE. RETAINED BACKFILL MATERIAL SHALL HAVE A MINIMUM FRICTION ANGLE OF 25 DEGREES, EXCEPT IN THE REINFORCED ZONE. BACKFILL MATERIAL TO BE USED IN THE REINFORCED ZONE SHALL BE 5M OR BETTER WITH MINIMUM FRICTION ANGLE OF 30 DEGREES.
 - CHIMNEY DRAIN ADJACENT TO MODULAR WALL UNITS AND MATERIAL USED TO FILL MODULAR WALL UNITS SHALL BE VIBRATORY PLATE COMPACTED NO. 57 STONE, OR A WELL GRADED COMPACTIBLE NO. 21A STONE, 1/4" TO 1 1/2" DIAMETER WITH NO MORE THAN 10% PASSING THE #200 SIEVE.
 - PLACE A 4" DIAMETER PERFORATED PVC DRAIN PIPE WRAPPED IN FILTER CLOTH ADJACENT TO INSIDE FACE OF THE MODULAR CONCRETE UNIT RETAINING WALL. PROVIDE DRAINAGE TO DAYLIGHT.
 - ANY VARIATION IN LOCATION OR ELEVATION OF RETAINING WALL, ELEVATION IN THE GRADE EITHER ABOVE OR BELOW THE WALL, OR THE RECOMMENDED INSTALLATION DETAILS, REQUIRE REVIEW BY THE ENGINEER OF RECORD.
 - ALL GEOSGRID REINFORCEMENT TO BE MIRAGRID 3XT SERIES MANUFACTURED BY TENCATE GEOSYNTHETICS. LENGTH OF GEOSGRID SHOWN ON DRAWINGS IS TAKEN FROM OUTSIDE FACE OF RETAINING WALL. GEOSGRID SHALL BE PULLED TAUGHT PRIOR TO INFILLING BACKFILL.
 - SEGMENTAL RETAINING WALL UNITS SHALL BE DIAMOND PRO MANUFACTURED BY ANCHOR WALL SYSTEMS, LLC.
 - CONTRACTOR SHALL FOLLOW INSTRUCTIONS PROVIDED BY BLOCK MANUFACTURER REGARDING THE CONSTRUCTION OF THE MODULAR CONCRETE UNIT WALLS. ANY INSTRUCTIONS THAT DIFFER FROM THOSE INDICATED ON THE CONSTRUCTION DRAWINGS SHALL BE BROUGHT TO THE ATTENTION OF THE ENGINEER OF RECORD PRIOR TO CONSTRUCTION.
 - PEDESTRIAN PROTECTION IS REQUIRED WHEN WALL HEIGHT EXCEEDS 30" ABOVE FINISH GRADE. GUARD RAILING, FENCING, AND/OR LANDSCAPE SHRUBBERY SHALL BE PROVIDED WHERE WALL HEIGHT EXCEEDS 30" ABOVE FINISH GRADE.
 - RETAINING WALL MINIMUM DESIGN SAFETY FACTORS:
 - OVERTURNING - 2.0
 - SLIDING - 1.5

APPROX. CL.	APPROXIMATE CENTERLINE	MIN. REINF.	MINIMUM ON CENTER REINFORCEMENT
DIA.	DIAMETER	STA.	STATION
EX.	EXISTING	TYP.	TYPICAL
MAX.	MAXIMUM	IV	WITH

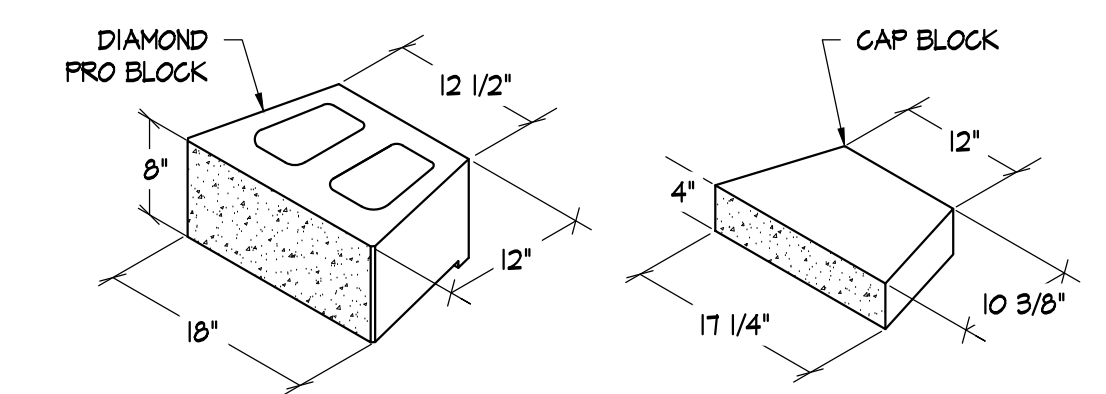

DETAIL
SCALE: NONE
TYPICAL ANCHOR DIAMOND PRO UNITS

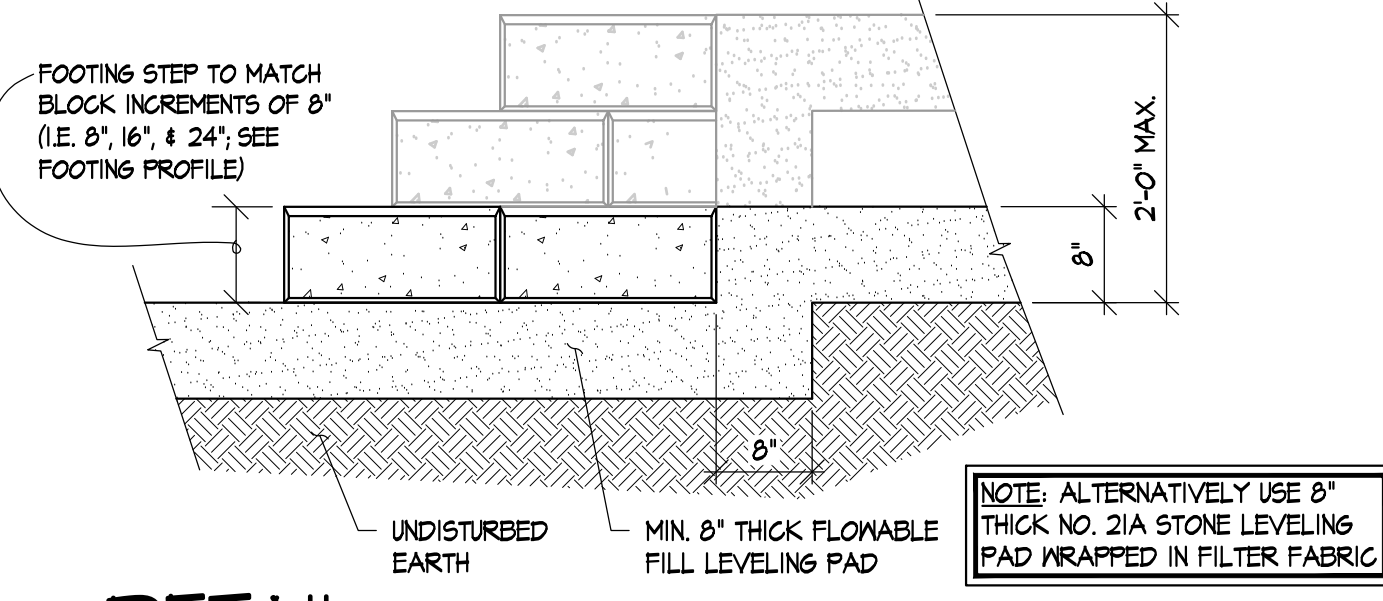
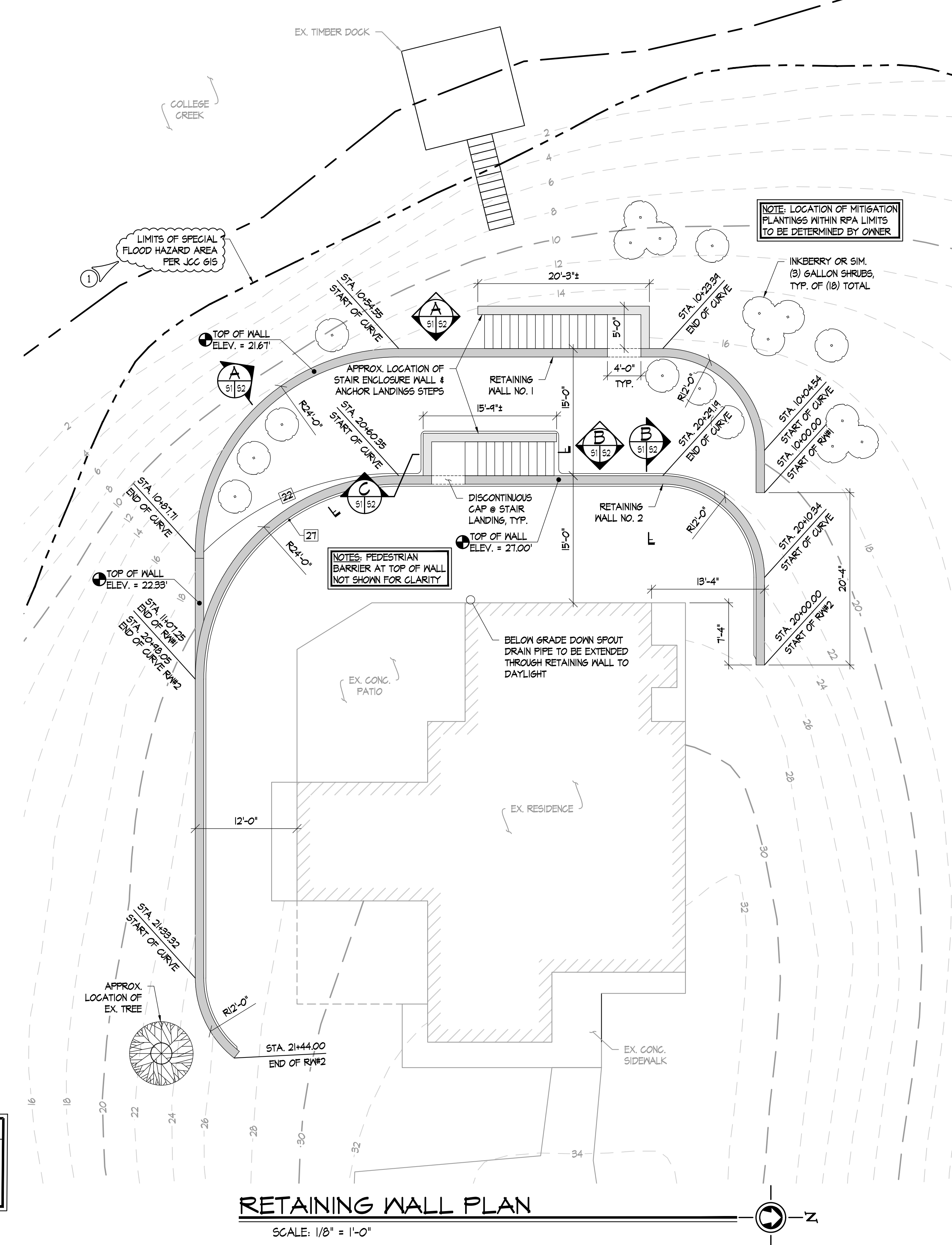

DETAIL
SCALE: 3/4\"/>

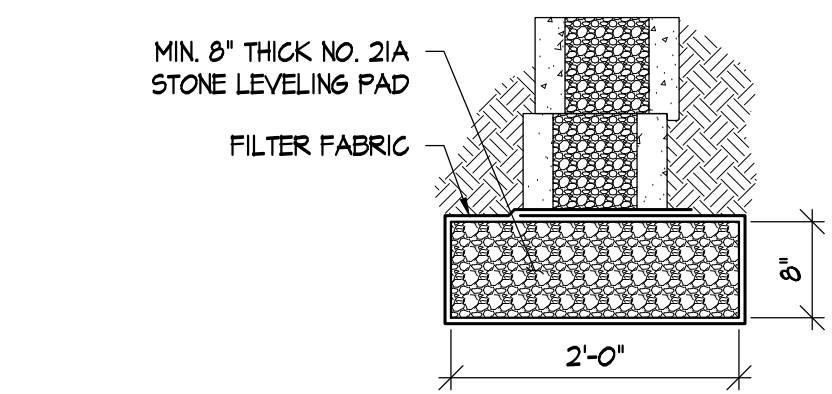

DETAIL
SCALE: 3/4\"/>

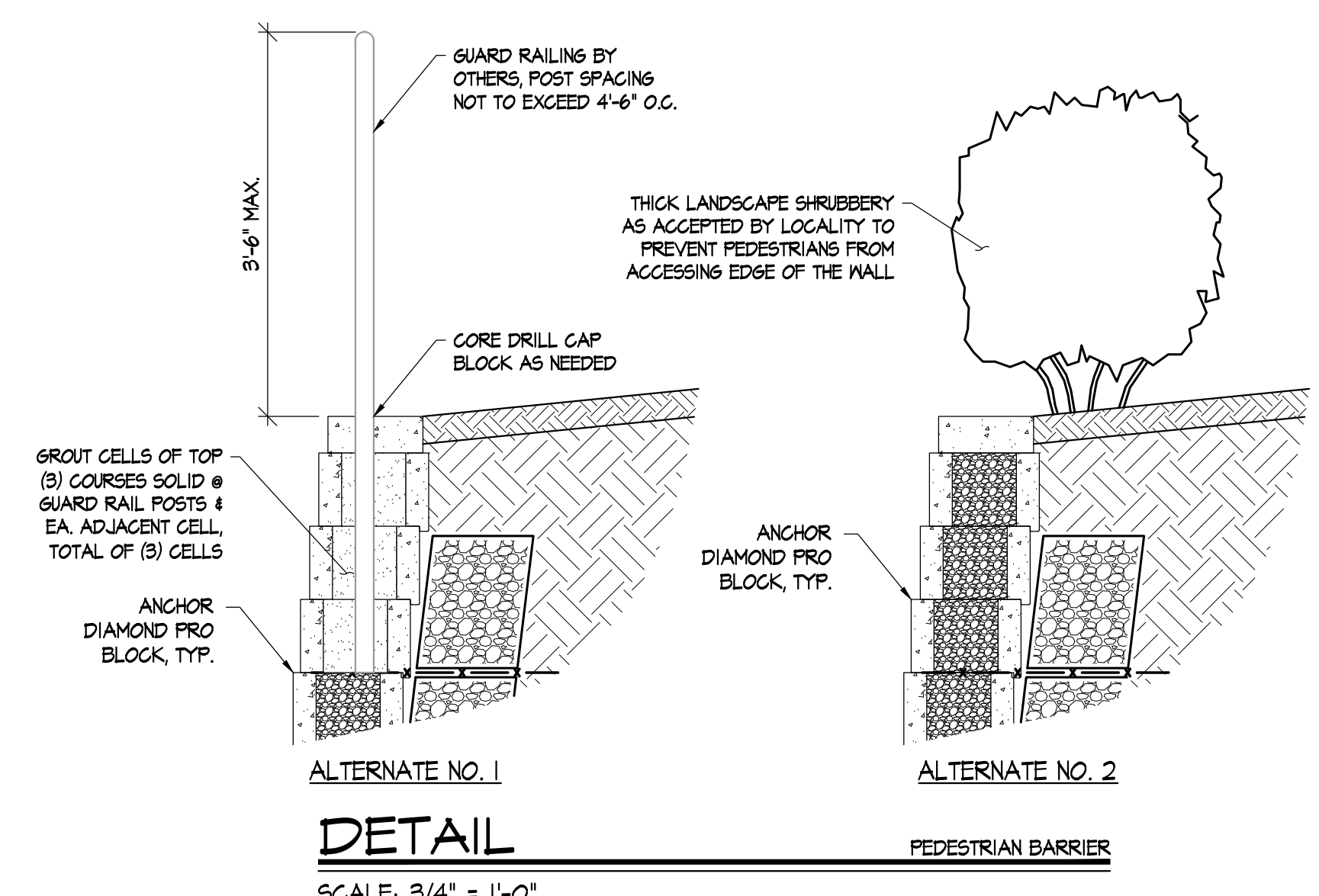

DETAIL
SCALE: 3/4\"/>

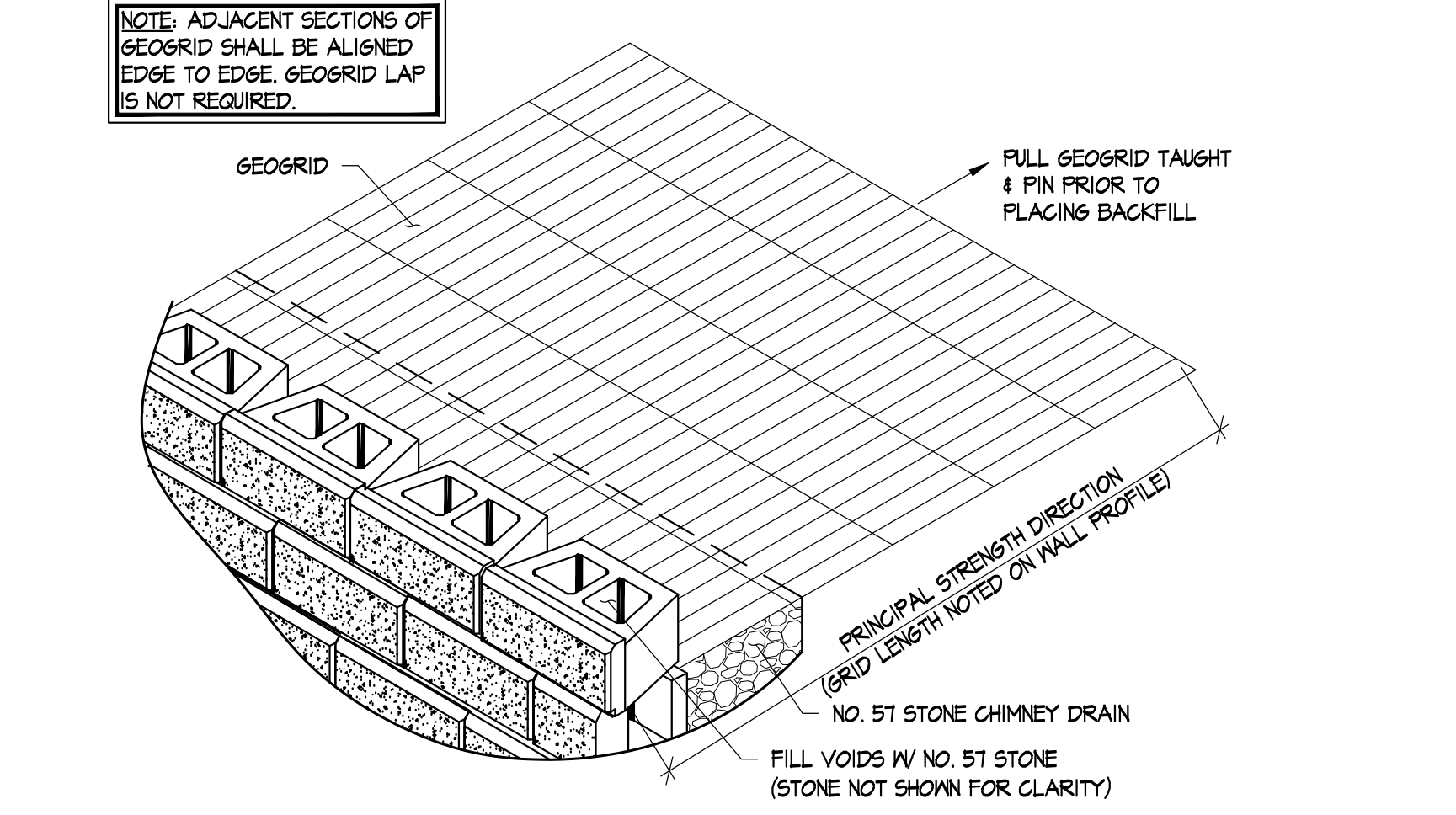

DETAIL
SCALE: 3/4\"/>

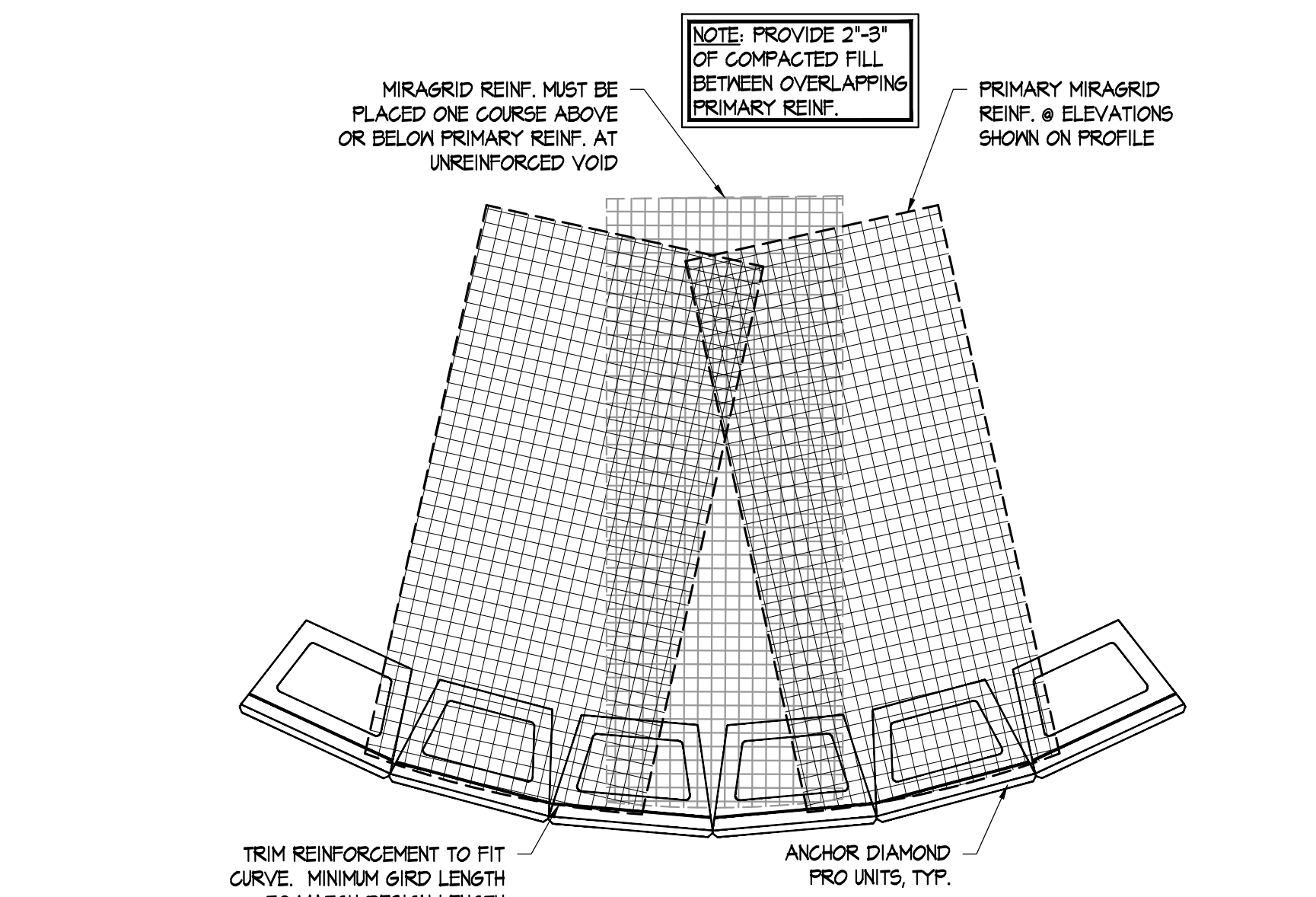

DETAIL
SCALE: 3/4\"/>

Project #: VA18090DES Drawn by: KJP Reviewed by: MAM

Date: 8/1/18

Professional Seal: MICHAEL A. MATTHEWS, License No. 017663, State of Virginia, Professional Engineer, 8/1/18

9/14/18

Zoning Plan Review Comments

Revisions

1

VA

RETAINING WALLS FOR ROBERTSON RESIDENCE 213 SOUTHPOINT DRIVE

JAMES CITY COUNTY

Sheet 2 of 3

The Structures Group, Inc. 1200 Old Colony Lane • Williamsburg, VA 23185 (757) 220-0465 • Fax (757) 220-1546 www.thestructuresgroup.com

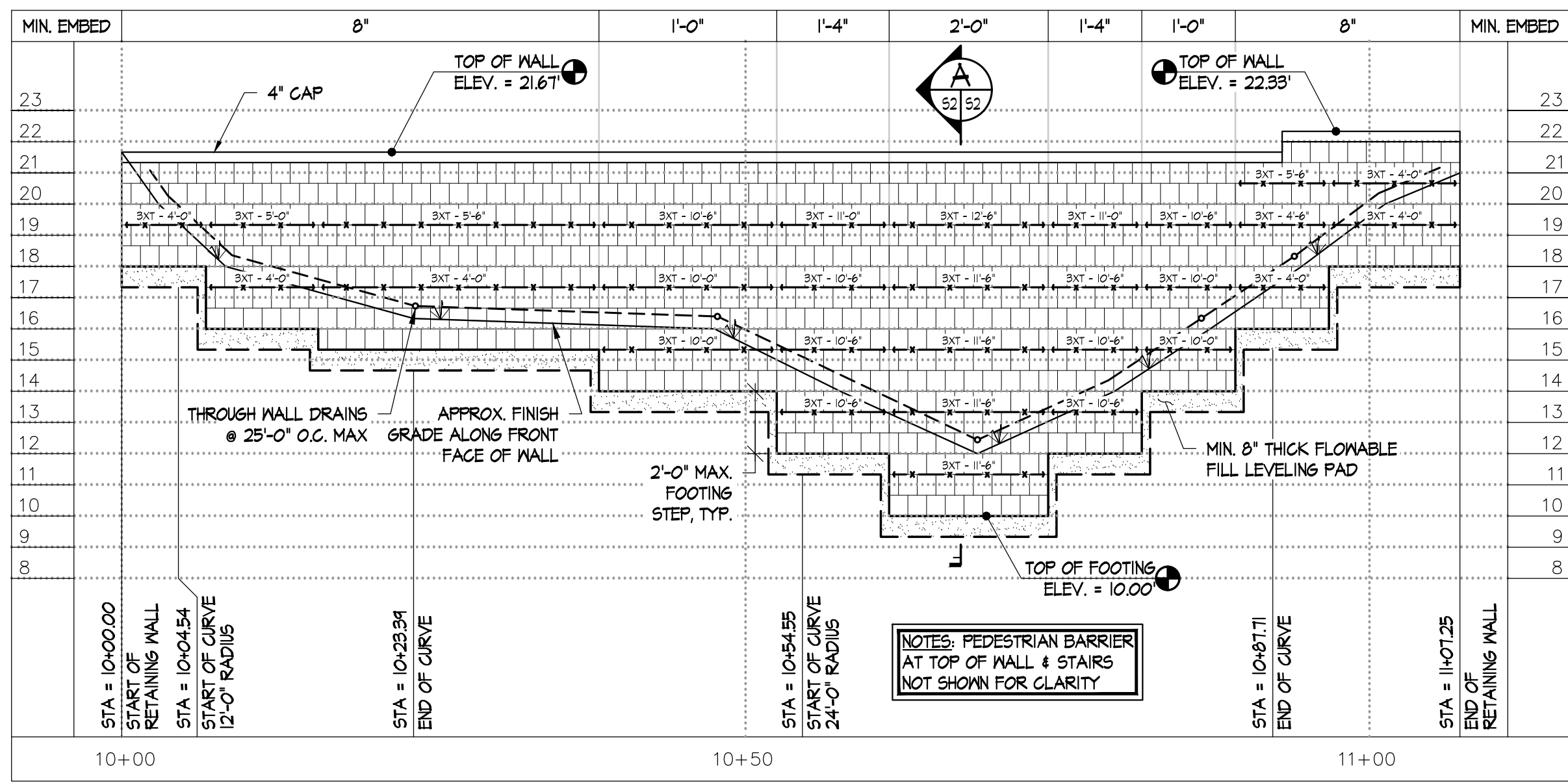

WALL PROFILE

HORIZ. SCALE: 1"=10'-0", VERT. SCALE: 1"=4'-0"

RETAINING WALL NO. 1
A
5/15

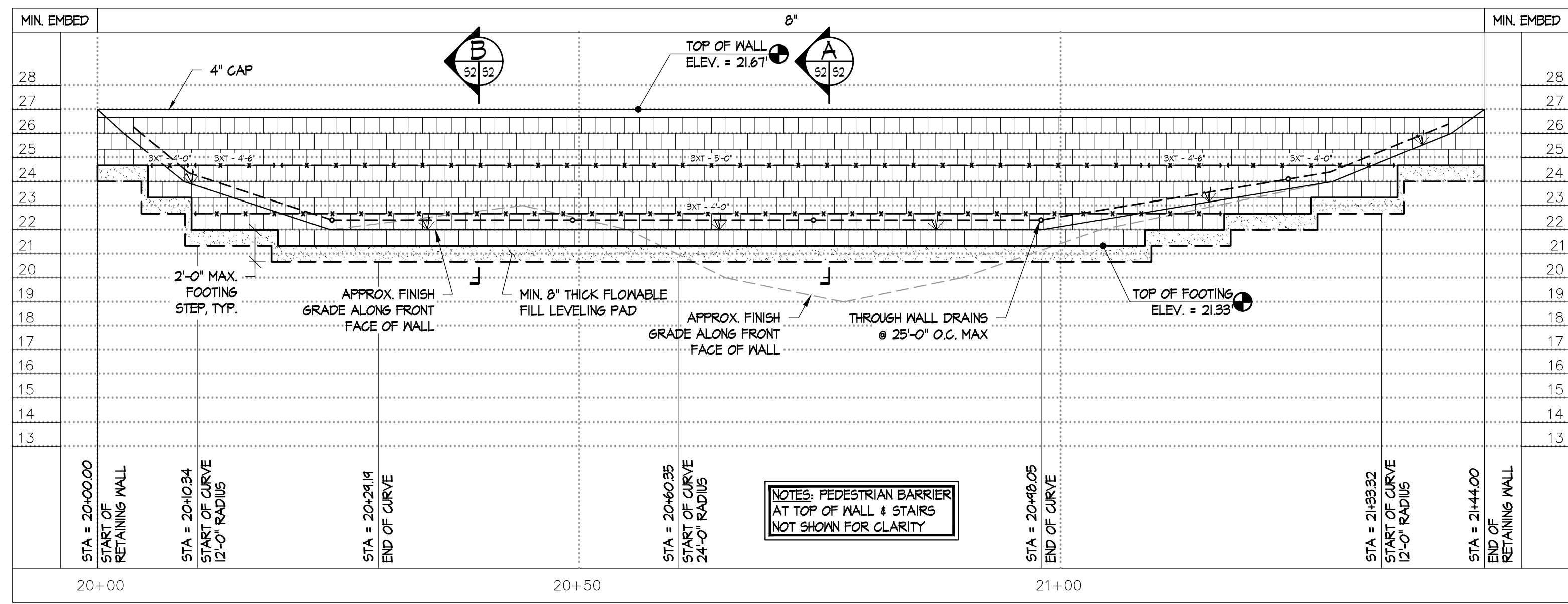

WALL PROFILE

HORIZ. SCALE: 1"=10'-0", VERT. SCALE: 1"=4'-0"

RETAINING WALL NO. 2
B
5/15

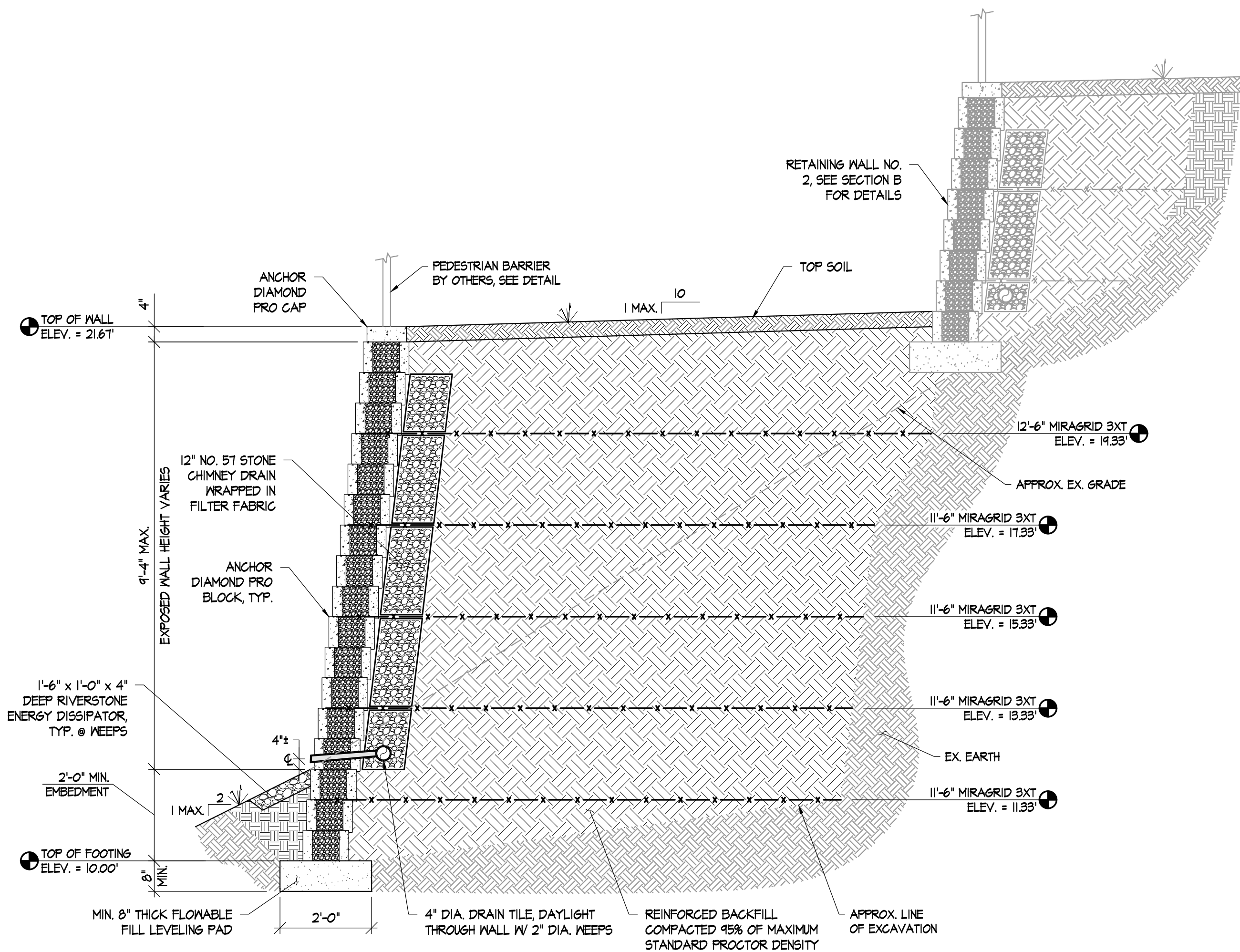

SECTION

SCALE: 1/2"=1'-0"

A
5/15

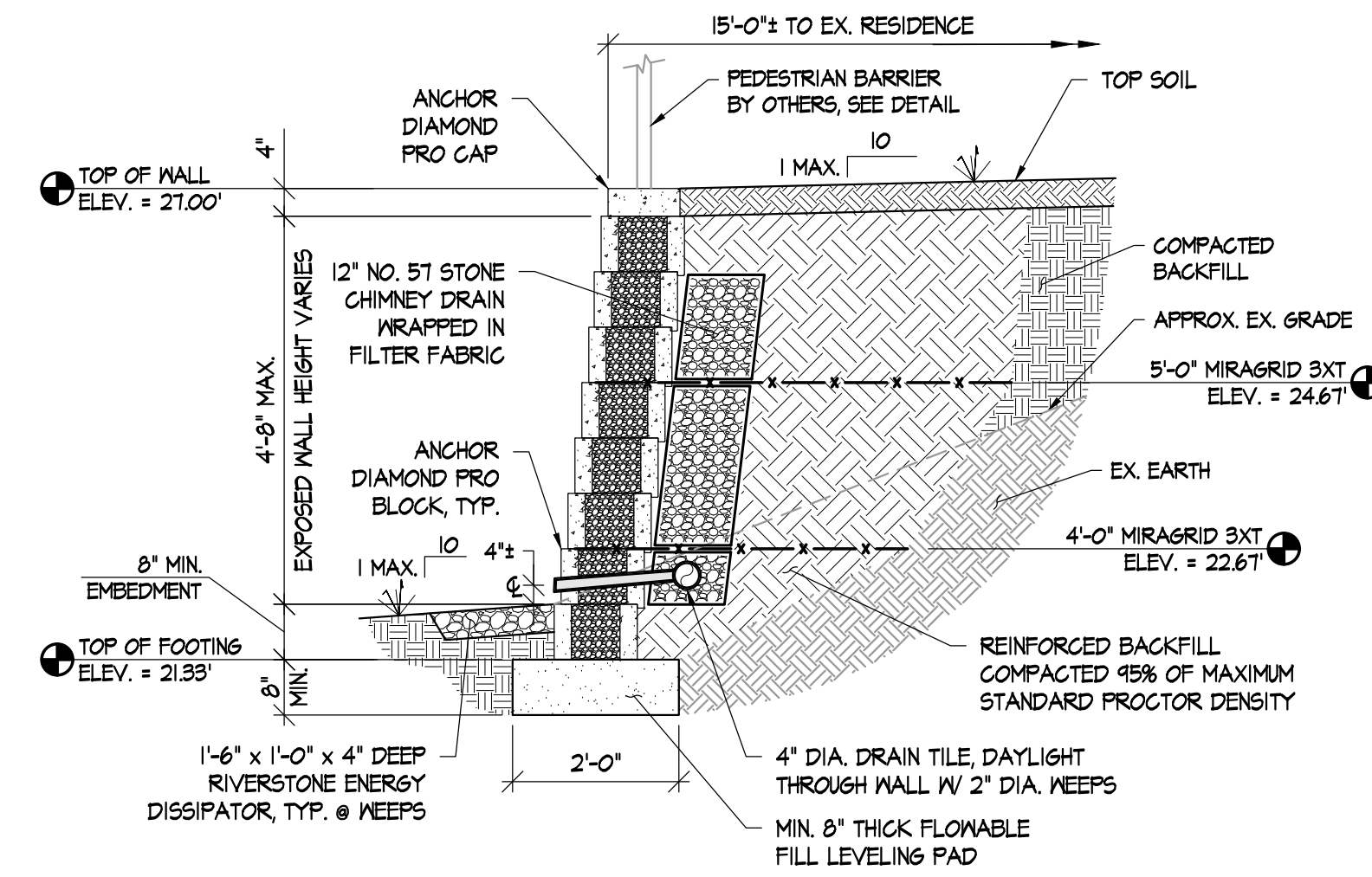

SECTION

SCALE: 1/2"=1'-0"

B
5/15

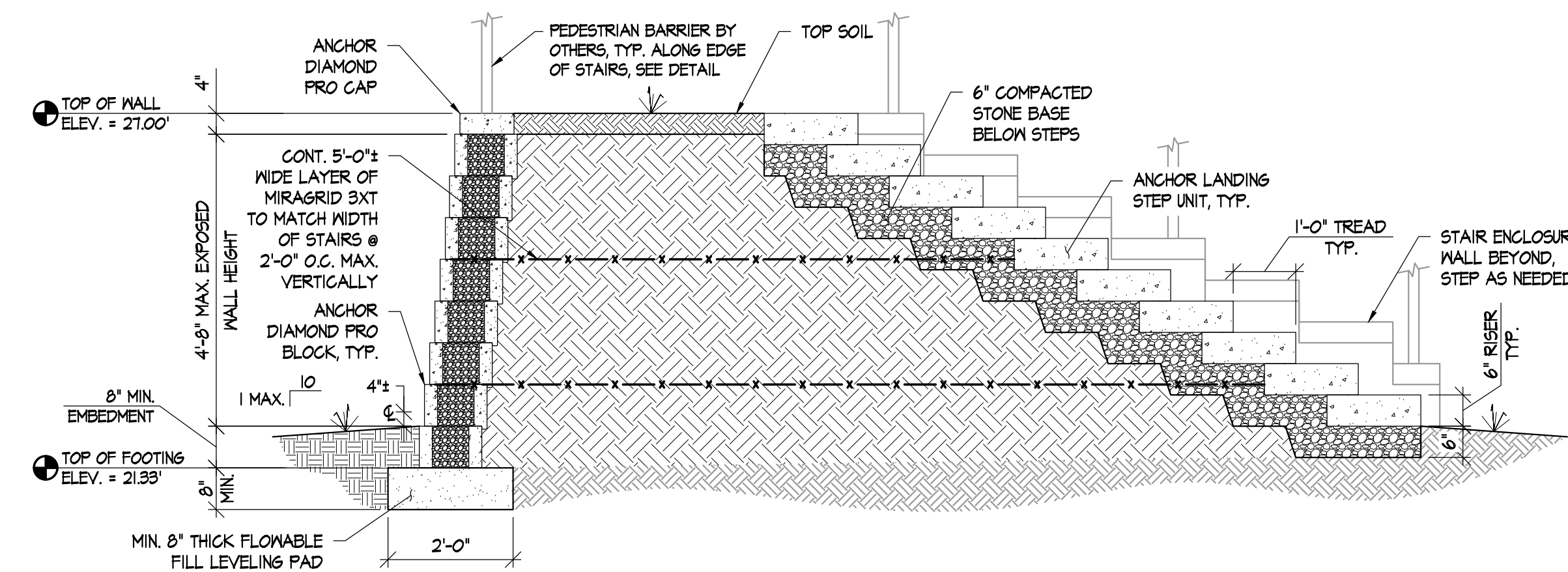

SECTION

SCALE: 1/2"=1'-0"

C
5/15

Sheet: RETAINING WALL PROFILES & SECTIONS

Date: 8/1/18

Project #: VA180904DES

Drawn by: KJP

Reviewed by: MAM

Revisions

VA No. 3 of 3

RETAINING WALLS FOR
ROBERTSON RESIDENCE
213 SOUTHPOINT DRIVE
JAMES CITY COUNTY

Sheet
S2

The Structures Group, Inc.
1200 Old Colony Lane • Williamsburg, VA 23185
(757) 220-0465 • Fax (757) 220-1546
www.thestructuresgroup.com

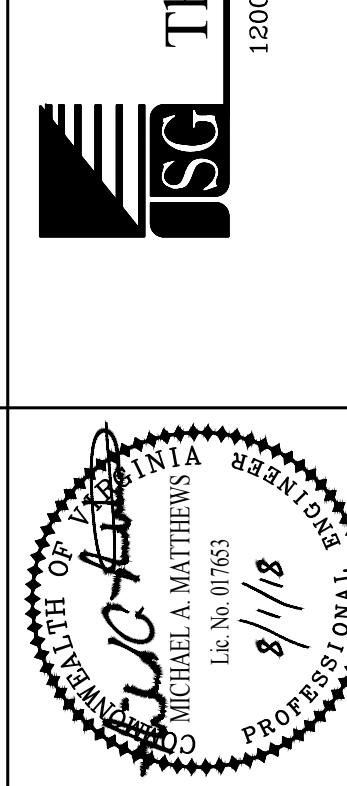

ITEM SUMMARY

DATE: 9/12/2018
TO: Chesapeake Bay Board
FROM: Chesapeake Bay Board Secretary
SUBJECT: CBPA 18-0126 : 3936 Vass Lane

ATTACHMENTS:

	Description	Type
☐	Staff Report	Cover Memo
☐	Resolution	Cover Memo
☐	APO Mailing List	Cover Memo
☐	APO Letter	Cover Memo
☐	Site Plan	Cover Memo

REVIEWERS:

Department	Reviewer	Action	Date
Chesapeake Bay Group	Geissler, Fran	Approved	9/5/2018 - 3:45 PM
Chesapeake Bay Group	Geissler, Fran	Approved	9/5/2018 - 3:46 PM
Publication Management	Burcham, Nan	Approved	9/5/2018 - 4:09 PM
Chesapeake Bay Group	Secretary, ChesBay	Approved	9/6/2018 - 7:13 AM

**CHESAPEAKE BAY BOARD EXCEPTION No. CBPA-18-0126. 3936 Vass Lane
Staff Report for the September 12, 2018, Chesapeake Bay Board Public Hearing**

This staff report is prepared by James City County Stormwater and Resource Protection to provide information to the Chesapeake Bay Board to assist them in making a recommendation on this assessment. It may be useful to members of the general public interested in this assessment.

EXISTING SITE DATA AND INFORMATION

Applicant: Mr. John Hyland
Agent: None
Location: 3936 Vass Lane
Tax Map/Parcel No.: 3842100009
Parcel: Lot 9, Vass Meadows
Lot Size: 0.19 acre
Area of Lot in Resource Protection Area (RPA): 0.16 acre +/- (84%)
Watershed: Mill Creek, (HUC JL33)
Floodplain: None
Proposed Activity: Construction of a workshop
Impervious Cover: 600 square feet
RPA Encroachment: 600 square feet, landward 50-foot RPA buffer
Staff Contact: Trevor Long, Watershed Planner Phone: 253-6789

BRIEF SUMMARY AND DESCRIPTION OF ACTIVITIES

Mr. John Hyland has applied for a Chesapeake Bay Exception for encroachments into the RPA buffer for the construction of a workshop on property located at 3936 Vass Lane within the Vass Meadows subdivision and the Mill Creek watershed. The property is further identified as James City County Tax Map Parcel No. 3842100009. The parcel was platted in 1994 after the adoption of the Chesapeake Bay Preservation Ordinance in 1990.

The total impervious cover within the RPA is 600 square feet within the landward 50-foot RPA. County requirements for this amount of encroachment would be one canopy tree, two understory trees and three shrubs. The applicant has proposed the plantings of three native trees, six shrubs and six to 12 square feet of mulch, therefore exceeding County mitigation requirements.

STAFF EVALUATION

Staff has evaluated the application and exception request for the construction of a workshop and finds the application meets the conditions in Sections 23-11 and 23-14, and the application should be heard by the Board

because the proposed workshop is considered accessory. Therefore, this request must be considered by the Board following a public hearing under the formal exception process.

WATER QUALITY IMPACT ASSESSMENT (WQIA)

A WQIA must be submitted, per Sections 23-11 and 23-14 of the County Ordinance, for any proposed land disturbing activity resulting from development or redevelopment within RPAs. To date, the applicant has submitted the required information as outlined in the *James City County Water Quality Impact Assessment Guidelines*.

CONSIDERATION BY THE CHESAPEAKE BAY BOARD

The exception granting body is permitted to require reasonable and appropriate conditions in granting the exception request in accordance with Section 23-14. The Chesapeake Bay Board should fully consider Chesapeake Bay Exception CBPA-18-0126 as outlined and presented above and review the request for exception along with the WQIA. The Board may grant the exception with such conditions and safeguards as deemed necessary to further the purpose and intent of the County's Chesapeake Bay Preservation Ordinance.

STAFF RECOMMENDATIONS

Staff has reviewed the application and exception request and has determined impacts associated with the proposal to be minor for the proposed development. Staff recommends approval of this exception request with the following conditions incorporated into the approval:

1. The applicant must obtain all other necessary federal, state and local permits as required for the project.
2. The applicant submit a \$500 surety made acceptable to the James City County Attorney to guarantee the plantings.
3. This exception request approval shall become null and void if construction has not begun by September 12, 2019.
4. Written requests for an extension to an exception shall be submitted to the Stormwater and Resource Protection Division no later than six weeks prior to the expiration date.

TL/nb
CBPA18-126-3936VassLn

Attachments:

1. Resolution
2. Water Quality Impact Assessment Package
3. Site Plan

RESOLUTION

CASE NO. CBPA-18-0126. 3936 VASS LANE

JAMES CITY COUNTY CHESAPEAKE BAY PRESERVATION ORDINANCE EXCEPTION

WHEREAS, Mr. John Hyland (the "Applicant") has applied to the Chesapeake Bay Board of James City County (the "Board") on September 12, 2018, to request an exception to use the Resource Protection Area (the "RPA") on a parcel of property identified as James City County Real Estate Tax Map Parcel No. 3842100009 and further identified as 3936 Vass Lane (the "Property") as set forth in the application CBPA-18-0126 for the purpose of the construction of a workshop; and

WHEREAS, the Board has listened to the arguments presented and has carefully considered all evidence entered into the record.

NOW, THEREFORE, BE IT RESOLVED that the Chesapeake Bay Board of James City County, Virginia, following a public hearing, by a majority vote of its members FINDS that:

1. The exception request is the minimum necessary to afford relief.
2. Granting the exception will not confer upon the Applicant any special privileges denied by Chapter 23, Chesapeake Bay Preservation, of the James City County Code, to other property owners similarly situated in the vicinity.
3. The exception request will be in harmony with the purpose and intent of Chapter 23 of the James City County Code and is not of substantial detriment to water quality.
4. The exception request is not based on conditions or circumstances that are self-created or self-imposed, nor does the request arise from conditions or circumstances either permitted or non-conforming that are related to adjacent parcels.
5. Reasonable and appropriate conditions are hereby imposed, as set forth below, which will prevent the exception request from causing a degradation of water quality.
6. In granting this exception, the following conditions are hereby imposed to prevent this exception request from causing degradation of water quality:
 - a. The applicant must obtain all other necessary federal, state and local permits required for the project.
 - b. The applicant submit a \$500 surety made acceptable to the James City County Attorney to guarantee the plantings.
 - c. This exception request approval shall become null and void if construction has not begun by September 12, 2019.

- d. Written requests for an extension to an exception shall be submitted to the Stormwater and Resource Protection Division no later than six weeks prior to the expiration date.

David Gussman
Chair, Chesapeake Bay Board

Michael D. Woolson
Senior Watershed Planner

Adopted by the Chesapeake Bay Board of James City County, Virginia, this 12th day of September, 2018.

THE FOREGOING INSTRUMENT WAS ACKNOWLEDGED BEFORE ME THIS ____ DAY OF _____, 20__ IN THE COMMONWEALTH OF VIRGINIA, IN THE COUNTY OF JAMES CITY.

NOTARY PUBLIC

MY COMMISSION EXPIRES: _____

CBPA18-126-3936VassLn-res

Mailing List for: CBPA-18-0126 – 3936 Vass Lane – Hyland – Workshop

Owner: 3842100009

Hyland, John

3936 Vass Lane

Williamsburg, VA 23188-2508

3842100010

Coronado, Gualberto T & Joanna M

3932 Vass Lane

Williamsburg, VA 23188-2592

3842100008

Devore, Adam Israel & Lisa Stella

3933 Vass Lane

Williamsburg, VA 23188-2508

3842100001A-3926 Vass Lane

The Mill Associates

319 S Boundary Street

Williamsburg, VA 23185-4005



General Services
Stormwater and Resource
Protection Division
101-E Mounts Bay Road
Williamsburg, VA 23185
757-253-6790

Resource.Protection@jamescitycountyva.gov

August 22, 2018

RE: CBPA-18-0126 – 3936 Vass Lane
Detached Workshop

Dear Adjacent Property Owner:

In accordance with State and County Codes, this letter is to notify you that a request has been filed with the James City County Chesapeake Bay Board by John Hyland for encroachment into the Resource Protection Area (RPA) buffer associated with the construction of a detached workshop. The project is located at 3936 Vass Lane in the Vass Meadows subdivision and is further identified as JCC Parcel No. 3842100009.

A complete description, plan and other information are on file in the Stormwater and Resource Protection Division and are available for inspection during normal business hours should anyone desire to review them.

The Chesapeake Bay Board will hold an advertised public hearing on **Wednesday, September 12, 2018 at 5:00 p.m.**, in the Board Room of Building F, 101-F, Mounts Bay Road, James City County, Virginia, at which time you may request to speak on the above referenced project.

Sincerely,

Janice Petty

Janice Petty
Stormwater Assistant

cc: Applicant /Owner
The Structures Group/Contractor

NOTES:

1. THIS PLAT WAS PRODUCED WITHOUT THE BENEFIT OF A TITLE REPORT AND REFLECTS ONLY THOSE ENCUMBRANCES, EASEMENTS AND SETBACKS AS SHOWN IN P.B. 59 PGS. 39-40.
2. THIS FIRM IS NOT RESPONSIBLE FOR THE LOCATION OF ANY STRUCTURE, MANHOLE, VALVE, ETC., HIDDEN OR OBSTRUCTED AT THE TIME THE FIELD SURVEY WAS PERFORMED.
3. LOT LIES IN F.I.R.M. ZONE "X" ACCORDING TO FLOOD INSURANCE RATE MAP #51095C0138D, DATED DECEMBER 16, 2015.
4. WETLANDS, IF ANY, WERE NOT LOCATED FOR THIS SURVEY.
5. UNDERGROUND UTILITIES WERE NOT LOCATED.

CURVE	RADIUS	ARC LENGTH	CHORD LENGTH	CHORD BEARING	DELTA ANGLE
C1	50.00'	37.69'	36.81'	S 65°19'11" E	43°11'25"

ADDRESS:
3936 VASS LANE
JAMES CITY COUNTY, VIRGINIA

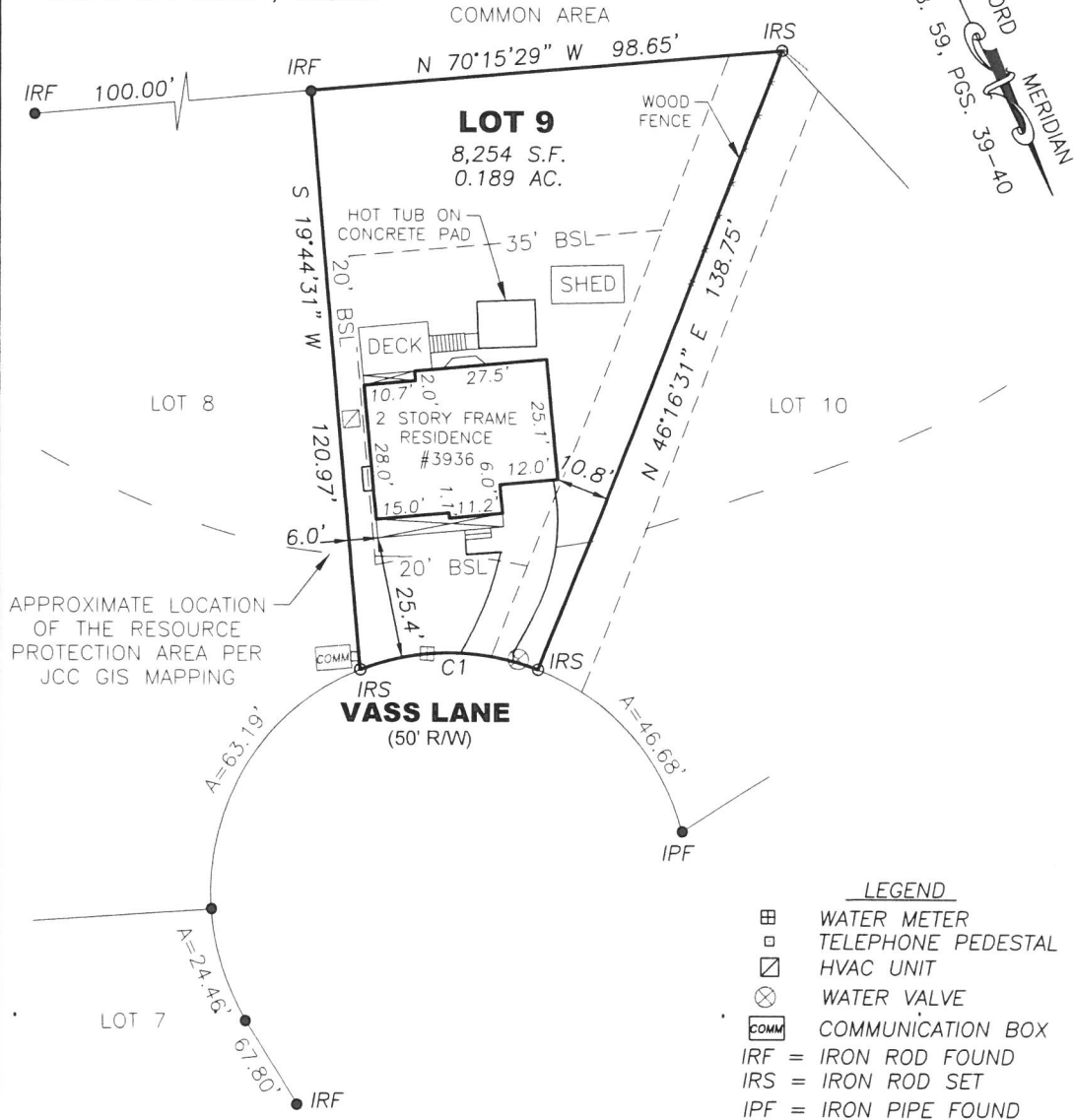

- LEGEND**
- ⊕ WATER METER
 - TELEPHONE PEDESTAL
 - ⊠ HVAC UNIT
 - ⊗ WATER VALVE
 - COMM COMMUNICATION BOX
 - IRF = IRON ROD FOUND
 - IRS = IRON ROD SET
 - IPF = IRON PIPE FOUND

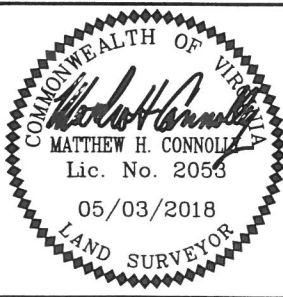

REFERENCES:
P.B. 59,
PGS. 39-40

DATE: 05/03/18
SCALE: 1"=30'
JOB# 18-157
CAD File
18-157.dwg

PHYSICAL SURVEY OF LOT 9,
VASS MEADOWS
For:
SEAN HYLAND
JAMES CITY COUNTY VIRGINIA

LandTech Resources, Inc.
Engineering & Surveying Consultants
3925 Midlands Road, Williamsburg, Virginia 23188
Telephone: 757-565-1677 Fax: 757-565-0782
Web: landtechresources.com

ITEM SUMMARY

DATE: 9/12/2018

TO: Chesapeake Bay Board

FROM: Michael Woolson, Senior Watershed Planner

SUBJECT: CBPA 18-0134 : 500 Thompson Lane

ATTACHMENTS:

	Description	Type
☐	Site Plan	Cover Memo
☐	APO Letter	Cover Memo
☐	APO Mailing List	Cover Memo
☐	Mitigation Plan	Cover Memo
☐	Public Notice	Cover Memo
☐	Staff Report	Cover Memo
☐	Resolution	Cover Memo

REVIEWERS:

Department	Reviewer	Action	Date
Chesapeake Bay Group	Geissler, Fran	Approved	9/5/2018 - 3:51 PM
Chesapeake Bay Group	Geissler, Fran	Approved	9/5/2018 - 3:51 PM
Publication Management	Burcham, Nan	Approved	9/5/2018 - 4:08 PM
Chesapeake Bay Group	Secretary, ChesBay	Approved	9/6/2018 - 1:23 PM

NOTES:
 LOW TIDE FOR THE CLOSEST TIDE TO THE SITE ON THE DATE THE SURVEY WAS PERFORMED WAS 9:23 A.M.
 FIELD LOCATION OF LOW WATER LINE OF GORDON CREEK WAS BETWEEN 8:45 AND 11:50.
 ELEVATIONS AND CONTOURS SHOWN ARE BASED OFF OF FIELD LOCATED LOW WATER LINE ON JUNE 26, 2015, HAVING AN ELEVATION OF 0.3 BASED ON COUNTY TIDE CHARTS.

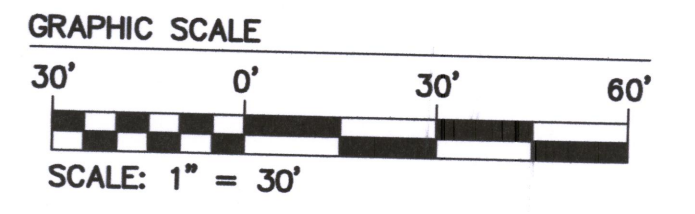

N/F
 SCOTT ARTHUR CARSWELL &
 R. CARSWELL
 #2691 JOLLY POND ROAD
 MAP #3610100003
 ZONED A1

- 1 canopy tree
- 2 understory trees
- 5 shrubs
- 1 rain garden
- 1 tree removal

N/F
 R.T. ARMISTEAD,
 LETITIA A.T. HANSON,
 MICHAEL J. CAVANAUGH, TRUSTEE
 #3783 BRICK BAT ROAD
 MAP #3520100016
 ZONED A1

PARCEL 2
 AREA=9.41± ACRES
 (DB 37, PG. 75)
 (AS SURVEYED TO
 LOW WATER)
 9.76 ACRES±

N/F
 JAMES LEE & BONNIE O'DONNELL
 MERSHON
 #500 THOMPSON LANE
 MAP #3610100005
 ZONED A1
 ALSO KNOWN AS
 WARBURTON'S POND
 PARCEL 1

N/F
 MARTHA W. MCMURRAN &
 SWR PINEWOOD, LL
 C/O MARTHA W. MCMURRAN
 #450 THOMPSON LANE
 MAP #3610100004
 ZONED A1

THIS DRAWING FOR REFERENCE ONLY

EXISTING CONDITIONS SURVEY
 of
 PROPERTY STANDING IN THE NAME OF
 JAMES LEE MERSHON AND BONNIE O'DONNELL MERSHON
 BEING 9.41 ACRES±
 POWHATAN DISTRICT JAMES CITY COUNTY VIRGINIA

AES
 CONSULTING ENGINEERS
 5248 Olde Towne Road, Suite 1
 Williamsburg, Virginia 23188
 Phone: (757) 253-0040
 Fax: (757) 220-8994
 www.aesva.com
 Hampton Roads | Central Virginia | Middle Peninsula



General Services
Stormwater and Resource
Protection Division
101-E Mounts Bay Road
Williamsburg, VA 23185
757-253-6790

Resource.Protection@jamescitycountyva.gov

August 22, 2018

RE: CBPA-18-0134 – 500 Thompson Lane
Demolition and construction of a Single Family Dwelling, Garage, Patio, Deck, Retaining Wall and Barn Addition

Dear Adjacent Property Owner:

In accordance with State and County Codes, this letter is to notify you that a request has been filed with the James City County Chesapeake Bay Board by N. Ross Thompson, III and Amy B. Thompson for encroachment into the Resource Protection Area (RPA) buffer associated with the demolition and construction of a single family dwelling, garage, patio, deck, retaining wall and barn addition. The project is located at 500 Thompson Lane and is further identified as JCC Parcel No. 3610100005.

A complete description, plan and other information are on file in the Stormwater and Resource Protection Division and are available for inspection during normal business hours should anyone desire to review them.

The Chesapeake Bay Board will hold an advertised public hearing on **Wednesday, September 12, 2018 at 5:00 p.m.**, in the Board Room of Building F, 101-F, Mounts Bay Road, James City County, Virginia, at which time you may request to speak on the above referenced project.

Sincerely,

Janice Petty

Janice Petty
Stormwater Assistant

cc: Applicant /Owner

Mailing List for: CBPA-18-0134 – 500 Thompson Lane – Thompson – Demo & replacement of Single Family Dwelling & Garage, new Patio, two Decks, Retaining Wall & Barn Tack Room Addition

Owner: 3610100005- 500 Thompson Lane

Thompson, Nathaniel R, III & Amy B
3209 Woodland Lane
Alexandria, VA 22309-2255

3610100003-2691 Jolly Pond Road

Carswell, Scott Arthur & Carswell, R
3921 Leaf Lawn Lane
Woodbridge, VA 22192

3520100015D

Hogge, Thomas H
2697 Jolly Pond Road
Williamsburg, VA 23188-7509

3520100015C

Pegram, David B & Tonya D
2711 Jolly Pond Road
Williamsburg, VA 23188-7511

3520100016-3783 Brick Bat Road

3630100001-4085 Centerville Road

Armistead, R T & Hanson, Letitia A T & Cavanaugh, Michael J
3804 Poplar Hill Road, Suite B
Chesapeake, VA 23321

3610100004-450 Thompson Lane

McMurrin, Martha W & SWR Pinewood LL c/o Martha W McMurrin
4200 Northside Parkway, NW, Building 10-101
Atlanta, GA 30327-3080

Mitigation Plan

Due to the size of the RPA encroachment, the required mitigation is 10 mitigation increments = 10 canopy trees, 20 understory trees, 30 shrubs. However, we plan to plant additional plantings, for a total of 15 canopy trees, 30 understory trees, and 45 shrubs.

Mitigation plan requirements:

- Any current and proposed buildings/structures. ***Marked on property survey.
- The 50' (seaward) and 100' (landward) RPA buffer areas. ***Marked on property survey.
- Any perennial streams, wetlands, or ponds on or adjacent to the property. ***Marked property on survey.
- All trees greater than 12" in diameter (measured 4.5' above the ground); include diameter and species or an outline of the wood lines if there are clumps of trees. ***Marked on property survey.
- Location of mitigation plantings (include species and size of planting). ***Marked on property survey. Proposed plantings include red maple, black walnut, sweetgum, pond pine, American beauty bush, silky dogwood, Virginia willow, and mountain laurel. Trees will be planted abutting Gordon's Creek/wetlands (back pasture); shrubs will be planted along the natural dam and abutting Gordon's Creek/wetlands (side area). Most of these plantings are also deer resistant.
- Location of other mitigation measures. ***Marked on property survey (rain gardens). Property is also awaiting a permit to replace and improve the bulkhead on the natural dam (this improvement will be completed in 2018). Recently installed (spring 2018) 11 aerators in the pond to improve and maintain water quality and vegetation in and near pond.
- Date of completion (no more than 24 months from approval). Owners would like to implement the mitigation plan prior to construction. The planting areas for the trees and shrubs are not in the construction area.
- Corresponding surety in a form acceptable to the County Attorney (certified check is preferred), must be submitted to ensure completion of the approved mitigation plan. Owners would like to implement the mitigation plan prior to construction. The planting areas for the trees and shrubs are not in the construction area.

Additionally requirements ...

- Mitigation plants will be native to the coastal plain of Virginia: www.dcr.virginia.gov/natural_heritage/nativeplants.shtml
- Mitigation plantings will be a mix of native, canopy trees, understory trees, and shrubs to provide an effective buffer.
- Mitigation plantings will be planted within the 100' RPA buffer.
- Canopy and understory trees will be a minimum of 1-1/2 inch caliper or 6 feet tall. Shrubs will be a minimum 3-gallon size and 18 inches tall.



PUBLIC HEARING NOTICE

THE WETLANDS AND CHESAPEAKE BAY BOARDS OF JAMES CITY COUNTY, VIRGINIA WILL HOLD A PUBLIC HEARING ON **WEDNESDAY, SEPTEMBER 12, 2018, AT 5 P.M.** IN THE BOARD ROOM OF BUILDING E, 101 MOUNTS BAY ROAD, JAMES CITY COUNTY, VIRGINIA.

THE WETLANDS BOARD WILL CONSIDER THE FOLLOWING CASE:

WJPA 18-0070/VMRC 17-0133: William & Mary Sailing Club has applied for a wetland permit to construct a floating dock at the Kingsmill Marina, 1010 Kingsmill Road in the Kingsmill on the James subdivision, JCC Parcel No. 5040100002C.

THE CHESAPEAKE BAY BOARD WILL CONSIDER THE FOLLOWING CASES:

CBPA 18-0129: Mr. Jeff Davis has filed an exception request for encroachment into the RPA buffer for the construction of a shed at 343 Neck-O-Land Road in the Berkeley District, JCC Parcel No. 4730100055.

CBPA 18-0134: Mr. and Mrs. N. Ross and Amy Thompson have filed an exception request for encroachment into the RPA buffer for the construction of a single family dwelling, deck, patio, retaining walls and a barn addition at 500 Thompson Lane in the Powhatan District, JCC Parcel No. 3610100005.

CBPA 18-0148: SeaWorld Parks and Entertainment has filed an exception request for encroachment into the RPA buffer for the construction of a new structure in the Festa Italia section of Busch Gardens Williamsburg at 7851 Pocahontas Trail, JCC Parcel No. 55140100009.

CBPA 18-0149: Ms. Meredith Robertson has filed an exception request for encroachment into the RPA buffer for the construction of two retaining walls at 213 Southpoint Drive in the Kingspoint subdivision, JCC Parcel No. 4930270014.

CBPA 18-0126: Mr. John Hyland has filed an exception request for encroachment into the RPA buffer for the construction of a detached workshop at 3936 Vass Lane in the Vass Meadows subdivision, JCC Parcel No. 3842100009.

CBPA 18-0131: Ms. Jean Walker has filed an exception request for encroachment into the RPA buffer for the construction of a retaining wall at 113 Wareham's Point in the Kingsmill on the James subdivision, JCC Parcel No. 5041900113.

Appeals from decisions under the Chesapeake Bay Preservation Ordinance may also be heard.

All interested parties are invited to attend the meetings. The applications and plans are on file and may be viewed during normal office hours in the Stormwater and Resource Protection Division, 101 Mounts Bay Road, Building E, James City County, Virginia.

**CHESAPEAKE BAY BOARD EXCEPTION No. CBPA-18-0134. 500 Thompson Lane
Staff Report for the September 12, 2018, Chesapeake Bay Board Public Hearing**

This staff report is prepared by James City County Stormwater and Resource Protection to provide information to the Chesapeake Bay Board to assist them in making a recommendation on this assessment. It may be useful to members of the general public interested in this assessment.

EXISTING SITE DATA AND INFORMATION

Applicants: Mr. Ross and Mrs. Amy Thompson

Agent: None

Location: 500 Thompson Lane

Tax Map/Parcel No.: 3610100005

Parcel: Warburton's Pond

Lot Size: 34.93 acres

Area of Lot in Resource Protection Area (RPA): 34.77 acres +/- (99%)

Watershed: Gordon Creek (HUC JL 29)

Floodplain: Zone AO and Zone X - Flood Depths of 1 to 3 feet with the base flood elevation determined to be 7 feet mean sea level

Proposed Activity: Construction of a single-family dwelling, garage, new patio, two decks, retaining wall and barn tack room addition

Impervious Cover: 3,877 square feet

RPA Encroachment: 3,877 square feet, landward 50-foot RPA buffer

Staff Contact: Trevor Long, Watershed Planner Phone: 253-6789

BRIEF SUMMARY AND DESCRIPTION OF ACTIVITIES

Mr. Ross and Mrs. Amy Thompson have applied for a Chesapeake Bay Exception for encroachments into the RPA buffer for the construction of a single-family dwelling, garage, new patio, two decks, retaining wall and barn tack room addition on property located at 500 Thompson Lane within the Gordon Creek watershed. The property is further identified as James City County Tax Map Parcel No. 3610100005. The parcel was platted in 1982, prior to the adoption of the Chesapeake Bay Preservation Ordinance.

Staff met with the applicants in June to discuss the scope of work and view the location of the proposed construction. Existing conditions of the lot include a single-family dwelling and garage that are slated to be replaced. The proposed home will include a patio and two decks. Additionally, the applicants propose to construct a tack room and retaining wall to prevent erosion on the property. Because 99% of the property is located in the RPA, nearly all work being done on the property will be within the RPA.

The proposed amount of encroachment into the RPA is 3,877 square feet. Mitigation required for this amount of encroachment into the RPA equates to 10 planting units. The applicant has proposed the plantings of 10 canopy trees, 20 understory trees, and 30 shrubs, therefore meeting County requirements for mitigation. The applicants have also proposed to enroll in the Turf Love program in addition to using gravel under the deck to mitigate stormwater runoff.

STAFF EVALUATION

Staff has evaluated the application and exception request for the proposed construction and additions and finds that the application meets the conditions in Sections 23-11 and 23-14 and that the application should be heard by the Board because some of the proposed construction is considered accessory in nature. Therefore, this request must be considered by the Board following a public hearing under the formal exception process. Per Sections 23-11 and 23-14 of the County Ordinance, a Water Quality Impact Assessment (WQIA) was submitted for the proposed project.

CONSIDERATION BY THE CHESAPEAKE BAY BOARD

The exception granting body is permitted to require reasonable and appropriate conditions in granting the exception request in accordance with Section 23-14. The Chesapeake Bay Board should fully consider Chesapeake Bay Exception CBPA-18-0134 as outlined and presented above and review the request for exception along with the WQIA. The Board may grant the exception with such conditions and safeguards as deemed necessary to further the purpose and intent of the County's Chesapeake Bay Preservation Ordinance.

STAFF RECOMMENDATIONS

Staff has reviewed the application and exception request and has determined impacts associated with the proposal to be minor for the proposed development. Staff recommends approval of this exception request with the following conditions incorporated into the approval:

1. The applicants must obtain all other necessary federal, state and local permits as required for the project.
2. All development activities located in the special flood hazard area shall comply with Article VI Division 3 Floodplain Area Regulations of the James City County Zoning Ordinance and receive all required approvals and permits prior to commencement of such activities.
3. A surety of \$3,000 in a form acceptable to the James City County Attorney to ensure the mitigation plantings and enrollment in the Turf Love program.
4. This exception request approval shall become null and void if construction has not begun by September 12, 2019.
5. Written requests for an extension to an exception shall be submitted to the Stormwater and Resource Protection Division no later than six weeks prior to the expiration date.

TL/md
CBPA18-0134Thompson

Attachments:

1. Resolution
2. Water Quality Impact Assessment Package
3. Site Plan
4. Mitigation Plan

RESOLUTION

CASE NO. CBPA-18-0134. 500 THOMPSON LANE

JAMES CITY COUNTY CHESAPEAKE BAY PRESERVATION ORDINANCE EXCEPTION

WHEREAS, Mr. Ross and Mrs. Amy Thompson (the “Applicants”) have applied to the Chesapeake Bay Board of James City County (the “Board”) on September 12, 2018, to request an exception to use the Resource Protection Area (the “RPA”) on a parcel of property identified as James City County Real Estate Tax Parcel No. 3610100005 and further identified as 500 Thompson Lane (the “Property”) as set forth in the application CBPA-18-0134 for the purpose of the construction of a single-family dwelling, garage, new patio, two decks, retaining wall and a barn tack room addition; and

WHEREAS, the Board has listened to the arguments presented and has carefully considered all evidence entered into the record.

NOW, THEREFORE, BE IT RESOLVED that the Chesapeake Bay Board of James City County, Virginia, following a public hearing, by a majority vote of its members FINDS that:

1. The exception request is the minimum necessary to afford relief.
2. Granting the exception will not confer upon the Applicants any special privileges denied by Chapter 23, Chesapeake Bay Preservation, of the James City County Code, to other property owners similarly situated in the vicinity.
3. The exception request will be in harmony with the purpose and intent of Chapter 23 of the James City County Code and is not of substantial detriment to water quality.
4. The exception request is not based on conditions or circumstances that are self-created or self-imposed, nor does the request arise from conditions or circumstances either permitted or non-conforming that are related to adjacent parcels.
5. Reasonable and appropriate conditions are hereby imposed, as set forth below, which will prevent the exception request from causing a degradation of water quality.
6. In granting this exception, the following conditions are hereby imposed to prevent this exception request from causing degradation of water quality:
 - a. The applicants must obtain all other necessary federal, state and local permits required for the project.
 - b. All development activities located in the special flood hazard area shall comply with Article VI, Division 3, Floodplain Area Regulations of the James City County Zoning Ordinance and receive all required approvals and permits prior to commencement of such activities.

- c. A surety of \$3,000 in a form acceptable to the James City County Attorney to ensure the mitigation plantings and enrollment in the Turf Love program.
- d. This exception request approval shall become null and void if construction has not begun by September 12, 2019.
- e. Written requests for an extension to an exception shall be submitted to the Stormwater and Resource Protection Division no later than six weeks prior to the expiration date.

David Gussman
Chair, Chesapeake Bay Board

Michael D. Woolson
Secretary to the Board

Adopted by the Chesapeake Bay Board of James City County, Virginia, this 12th day of September, 2018.

THE FOREGOING INSTRUMENT WAS ACKNOWLEDGED BEFORE ME THIS ____ DAY OF _____, 20__ IN THE COMMONWEALTH OF VIRGINIA, IN THE COUNTY OF JAMES CITY.

NOTARY PUBLIC

MY COMMISSION EXPIRES: _____

CBPA18-0134Thompson-res

ITEM SUMMARY

DATE: 9/12/2018
TO: Chesapeake Bay Board
FROM: Michael Woolson, Senior Watershed Planner
SUBJECT: CBPA 18-0148 : Busch Gardens, Madrid

ATTACHMENTS:

	Description	Type
☐	Public Notice	Cover Memo
☐	Mailing List	Cover Memo
☐	APO Letter	Cover Memo
☐	Site Plan	Cover Memo
☐	Staff Report	Cover Memo
☐	Resolution	Cover Memo

REVIEWERS:

Department	Reviewer	Action	Date
Chesapeake Bay Group	Geissler, Fran	Approved	9/5/2018 - 4:00 PM
Chesapeake Bay Group	Geissler, Fran	Approved	9/5/2018 - 4:00 PM
Publication Management	Burcham, Nan	Approved	9/5/2018 - 4:07 PM
Chesapeake Bay Group	Secretary, ChesBay	Approved	9/6/2018 - 1:23 PM



PUBLIC HEARING NOTICE

THE WETLANDS AND CHESAPEAKE BAY BOARDS OF JAMES CITY COUNTY, VIRGINIA WILL HOLD A PUBLIC HEARING ON **WEDNESDAY, SEPTEMBER 12, 2018, AT 5 P.M.** IN THE BOARD ROOM OF BUILDING E, 101 MOUNTS BAY ROAD, JAMES CITY COUNTY, VIRGINIA.

THE WETLANDS BOARD WILL CONSIDER THE FOLLOWING CASE:

WJPA 18-0070/VMRC 17-0133: William & Mary Sailing Club has applied for a wetland permit to construct a floating dock at the Kingsmill Marina, 1010 Kingsmill Road in the Kingsmill on the James subdivision, JCC Parcel No. 5040100002C.

THE CHESAPEAKE BAY BOARD WILL CONSIDER THE FOLLOWING CASES:

CBPA 18-0129: Mr. Jeff Davis has filed an exception request for encroachment into the RPA buffer for the construction of a shed at 343 Neck-O-Land Road in the Berkeley District, JCC Parcel No. 4730100055.

CBPA 18-0134: Mr. and Mrs. N. Ross and Amy Thompson have filed an exception request for encroachment into the RPA buffer for the construction of a single family dwelling, deck, patio, retaining walls and a barn addition at 500 Thompson Lane in the Powhatan District, JCC Parcel No. 3610100005.

CBPA 18-0148: SeaWorld Parks and Entertainment has filed an exception request for encroachment into the RPA buffer for the construction of a new structure in the Festa Italia section of Busch Gardens Williamsburg at 7851 Pocahontas Trail, JCC Parcel No. 55140100009.

CBPA 18-0149: Ms. Meredith Robertson has filed an exception request for encroachment into the RPA buffer for the construction of two retaining walls at 213 Southpoint Drive in the Kingspoint subdivision, JCC Parcel No. 4930270014.

CBPA 18-0126: Mr. John Hyland has filed an exception request for encroachment into the RPA buffer for the construction of a detached workshop at 3936 Vass Lane in the Vass Meadows subdivision, JCC Parcel No. 3842100009.

CBPA 18-0131: Ms. Jean Walker has filed an exception request for encroachment into the RPA buffer for the construction of a retaining wall at 113 Wareham's Point in the Kingsmill on the James subdivision, JCC Parcel No. 5041900113.

Appeals from decisions under the Chesapeake Bay Preservation Ordinance may also be heard.

All interested parties are invited to attend the meetings. The applications and plans are on file and may be viewed during normal office hours in the Stormwater and Resource Protection Division, 101 Mounts Bay Road, Building E, James City County, Virginia.

Mailing List for: CBPA-18-0148 – 7851 Pocahontas Trail– SeaWorld Parks – Madrid Expansion

Owner: 5140100009

SeaWorld Parks & Entertainment LLC c/o PTS
P.O. Box 543185
Dallas, TX 75354-3185

SeaWorld Parks and Entertainment
Attn: Kevin Lembke
One Busch Gardens Blvd
Williamsburg, VA 23185-8765

SeaWorld Parks & Entertainment LLC
9205 South Park Center Loop, Suite 400
Orlando, FL 32819-8651

5130100001 - 7801 Pocahontas Tr
5230100112 – 100 Busch Service Rd
Anheuser-Busch Brewing Properties, LLC
Attn: General Counsel
One Busch Place
Saint Louis, MO 63118-1849

5140100002 – 8397 Pocahontas Tr
Sturdivant, Toni C
8405 Pocahontas Trail
Williamsburg, VA 23185-5952

5140100003 – 8399 Pocahontas Tr
Lee, Robert and Rebecca
215 Telford Drive
Newport News VA 23602-5224

5130100002 – 1000 Carter's Grove
5230100011A – 8581 Pocahontas Tr
5230100111 - 8515 Pocahontas Tr
5230100011B – 101 Busch Service Rd
Escalante Kingsmill Development LLC
2930 Bledsoe Street, Suite 124
Fort Worth, TX 76107-2942



**General Services
Stormwater and Resource
Protection Division**
101-E Mounts Bay Road
Williamsburg, VA 23185

Resource.Protection@jamescitycountyva.gov

August 22, 2018

RE: CBPA-18-0148
Busch Gardens Festa Italia

Dear Adjacent Property Owner:

In accordance with State and County Codes, this letter is to notify you that a request has been filed with the James City County Chesapeake Bay Board by Kevin Lembke of SeaWorld Parks & Entertainment, LLC, for encroachment into the Resource Protection Area (RPA) buffer associated with the construction of a Festa Italia structure located within Busch Gardens Williamsburg at 7851 Pocahontas Trail and further identified as JCC Parcel No. 5140100009.

A complete description, plan and other information are on file in the Stormwater and Resource Protection Division and are available for inspection during normal business hours, should anyone desire to review them.

The Chesapeake Bay Board will hold an advertised public hearing on **Wednesday, September 12, 2018 at 5:00 p.m.**, in the Board Room of Building F, 101 Mounts Bay Road, James City County, Virginia, at which time you may request to speak on the above referenced project.

Sincerely,

Janice Petty

Janice Petty
Stormwater Assistant

cc: SeaWorld Parks & Entertainment, Suzy Cheely



351 McLaws Circle
Suite 3
Williamsburg, VA 23185
757.220.0500



- PROPOSED IMPERVIOUS AREA = 58795F
- TEMPORARY IMPACT 50' LANDWARD = 19404 SF
- TEMPORARY IMPACT 50' SEAWARD = 9565 SF

BGW Project Madrid

7851 Pocahontas Trail
Williamsburg, Virginia

No.	Revision	Date	Appr'd.

Designed by	Checked by
Issued for	Date

August 1, 2018

Not for Construction
Drawing Title
RPA Impact Exhibit

EXH - 2

Sheet 2 of 3

Project Number
33273.88





351 McLaws Circle
Suite 3
Williamsburg, VA 23185
757.220.0500



100' RPA BUFFER WITHIN
BUSCH GARDENS
PROPERTY

BGW Project Madrid

7851 Pocahontas Trail
Williamsburg, Virginia

No.	Revision	Date	App'd

Designed by	Checked by
Date	Date
August 1, 2018	

Not for Construction
RPA Impact Exhibit

EXH - 3

Sheet 3 of 3

Project Number
33273.88

Williamsburg

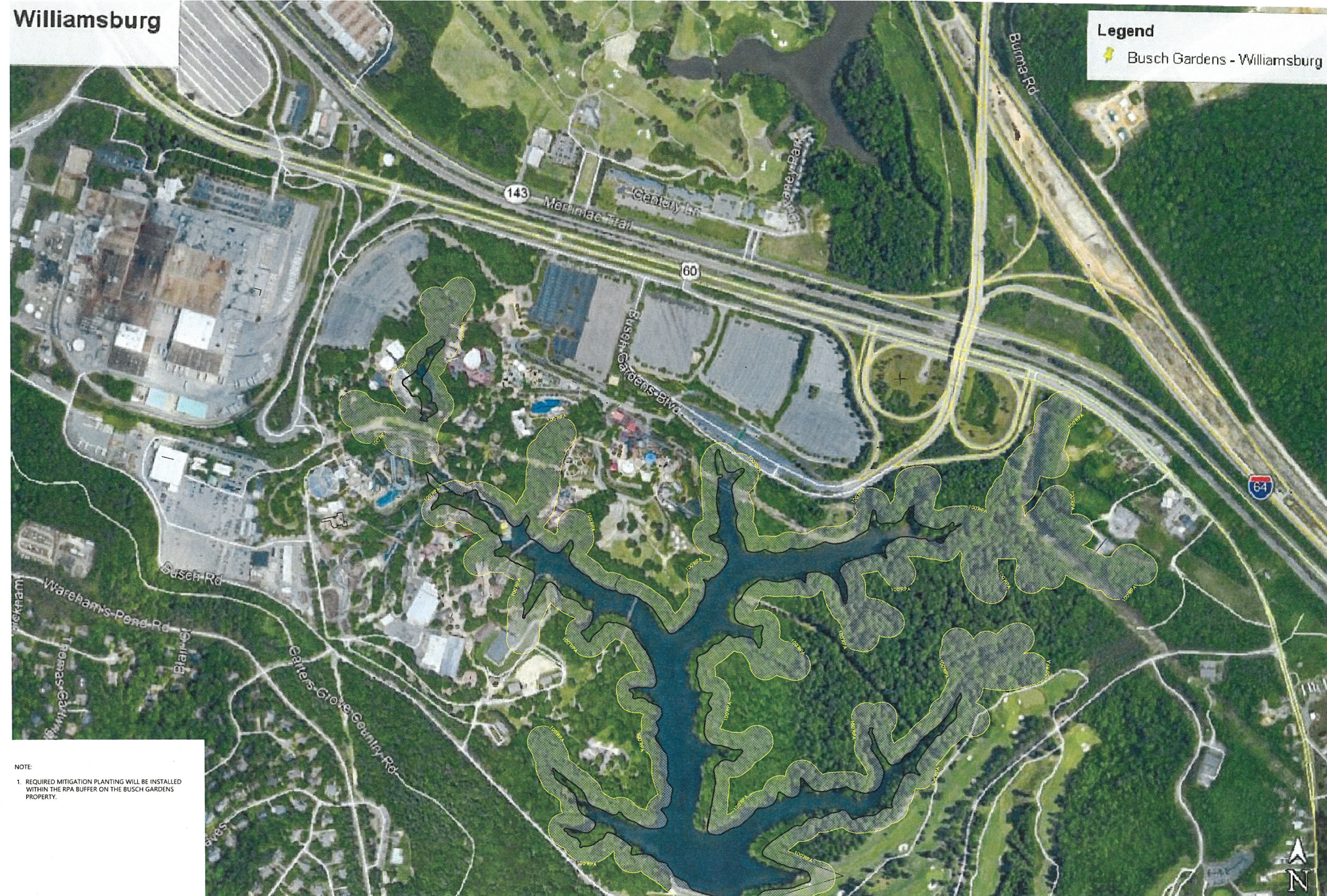

NOTE:
1. REQUIRED MITIGATION PLANTING WILL BE INSTALLED WITHIN THE RPA BUFFER ON THE BUSCH GARDENS PROPERTY.

**CHESAPEAKE BAY BOARD EXCEPTION No. CBPA-18-0148. 7851 Pocahontas Trail
Staff Report for the September 12, 2018, Chesapeake Bay Board Public Hearing**

This staff report is prepared by James City County Stormwater and Resource Protection to provide information to the Chesapeake Bay Board to assist them in making a recommendation on this assessment. It may be useful to members of the general public interested in this assessment.

EXISTING SITE DATA AND INFORMATION

Applicant: Seaworld Parks & Entertainment, LLC

Agent: Mr. Piotr Swietuchowski

Location: 7851 Pocahontas Trail

Tax Map/Parcel No.: 5140100009

Parcel: Busch Gardens Williamsburg

Lot Size: 383.07 acres

Area of Lot in Resource Protection Area (RPA): 130 acres +/- (39%)

Watershed: James River (HUC JL30)

Floodplain: Zone X - area determined to be outside of the 0.2% annual chance flood

Proposed Activity: Festa Italia expansion

Impervious Cover: 5,879 square feet

RPA Encroachment: 19,404 square feet, landward 50-foot RPA buffer
9,565 square feet, seaward 50-foot RPA buffer

Staff Contact: Trevor Long, Watershed Planner Phone: 253-6789

BRIEF SUMMARY AND DESCRIPTION OF ACTIVITIES

Mr. Piotr Swietuchowski has applied for a Chesapeake Bay Exception on behalf of Seaworld Parks & Entertainment, LLC for encroachments into the RPA buffer for the expansion of Festa Italia on property located at 7851 Pocahontas Trail within the James River watershed. The property is otherwise known as Busch Gardens Williamsburg and is further identified as James City County Tax Map Parcel No. 5140100009. The parcel was platted in 1974, prior to the adoption of the Chesapeake Bay Preservation Ordinance in 1990.

Due to the scale of the proposed expansion in relation to existing structures surrounding the project site, RPA encroachment is deemed unavoidable for this exception request. Additionally, this site is necessary to maintain the utility and mechanical connectivity with the rest of the park. The proposed amount of encroachment into the RPA is 28,969 square feet with approximately 5,879 square feet of impervious cover. The required vegetative mitigation for this amount of impervious cover is 15 planting units. The applicant has proposed the planting of 30 native canopy trees, 60 native understory trees and 90 native shrubs, thereby doubling the mitigation requirements of the County. Additionally, the applicant has proposed the use of a dry swale as a Best Management Practice to provide additional water quality treatment of the additional stormwater runoff.

STAFF EVALUATION

Staff has evaluated the application and exception request for the expansion and finds that the application meets the conditions in Sections 23-11 and 23-14 and that the application should be heard by the Board because the expansion encroaches into the seaward 50-foot RPA buffer. Therefore, this request must be considered by the Board following a public hearing under the formal exception process. Per Sections 23-11 and 23-14 of the County Ordinance, a Water Quality Impact Assessment (WQIA) was submitted for the proposed project.

CONSIDERATION BY THE CHESAPEAKE BAY BOARD

The exception granting body is permitted to require reasonable and appropriate conditions in granting the exception request in accordance with Section 23-14. The Chesapeake Bay Board should fully consider Chesapeake Bay Exception CBPA-18-0148 as outlined and presented above and review the request for exception along with the WQIA. The Board may grant the exception with such conditions and safeguards as deemed necessary to further the purpose and intent of the County's Chesapeake Bay Preservation Ordinance.

STAFF RECOMMENDATIONS

Staff has reviewed the application and exception request and has determined impacts associated with the proposal to be major for the proposed development. Staff recommends approval of this exception request with the following conditions incorporated into the approval:

1. The applicant must obtain all other necessary federal, state and local permits as required for the project.
2. A mitigation plan consistent with County requirements be submitted along with a surety of \$10,000 in a form acceptable to the James City County Attorney to ensure the mitigation.
3. This exception request approval shall become null and void if construction has not begun by September 12, 2019.
4. Written requests for an extension to an exception shall be submitted to the Stormwater and Resource Protection Division no later than six weeks prior to the expiration date.

TL/md
CBPA18-0148BGarden

Attachments:

1. Resolution
2. Water Quality Impact Assessment Package
3. Site Plan

RESOLUTION

CASE NO. CBPA-18-0148. 7851 POCAHONTAS TRAIL

JAMES CITY COUNTY CHESAPEAKE BAY PRESERVATION ORDINANCE EXCEPTION

WHEREAS, Seaworld Parks & Entertainment, LLC (the “Applicant”) has applied to the Chesapeake Bay Board of James City County (the “Board”) on September 12, 2018, to request an exception to use the Resource Protection Area (the “RPA”) on a parcel of property identified as James City County Real Estate Tax Parcel No. 5140100009 and further identified as 7851 Pocahontas Trail (the “Property”) as set forth in the application CBPA-18-0148 for the purpose of the Festa Italia expansion; and

WHEREAS, the Board has listened to the arguments presented and has carefully considered all evidence entered into the record.

NOW, THEREFORE, BE IT RESOLVED that the Chesapeake Bay Board of James City County, Virginia, following a public hearing, by a majority vote of its members FINDS that:

1. The exception request is the minimum necessary to afford relief.
2. Granting the exception will not confer upon the Applicant any special privileges denied by Chapter 23, Chesapeake Bay Preservation, of the James City County Code, to other property owners similarly situated in the vicinity.
3. The exception request will be in harmony with the purpose and intent of Chapter 23 of the James City County Code and is not of substantial detriment to water quality.
4. The exception request is not based on conditions or circumstances that are self-created or self-imposed, nor does the request arise from conditions or circumstances either permitted or non-conforming that are related to adjacent parcels.
5. Reasonable and appropriate conditions are hereby imposed, as set forth below, which will prevent the exception request from causing a degradation of water quality.
6. In granting this exception, the following conditions are hereby imposed to prevent this exception request from causing degradation of water quality:
 - a. The applicant must obtain all other necessary federal, state and local permits required for the project.
 - b. A mitigation plan consistent with County requirements be submitted along with a surety of \$10,000 in a form acceptable to the James City County Attorney to ensure the mitigation.

- c. This exception request approval shall become null and void if construction has not begun by September 12, 2019.
- d. Written requests for an extension to an exception shall be submitted to the Stormwater and Resource Protection Division no later than six weeks prior to the expiration date.

David Gussman
Chair, Chesapeake Bay Board

Michael D. Woolson
Secretary to the Board

Adopted by the Chesapeake Bay Board of James City County, Virginia, this 12th day of September, 2018.

THE FOREGOING INSTRUMENT WAS ACKNOWLEDGED BEFORE ME THIS ____ DAY OF _____, 20__ IN THE COMMONWEALTH OF VIRGINIA, IN THE COUNTY OF JAMES CITY.

NOTARY PUBLIC

MY COMMISSION EXPIRES: _____

CBPA18-0148BGarden-res